

**WAGNER**

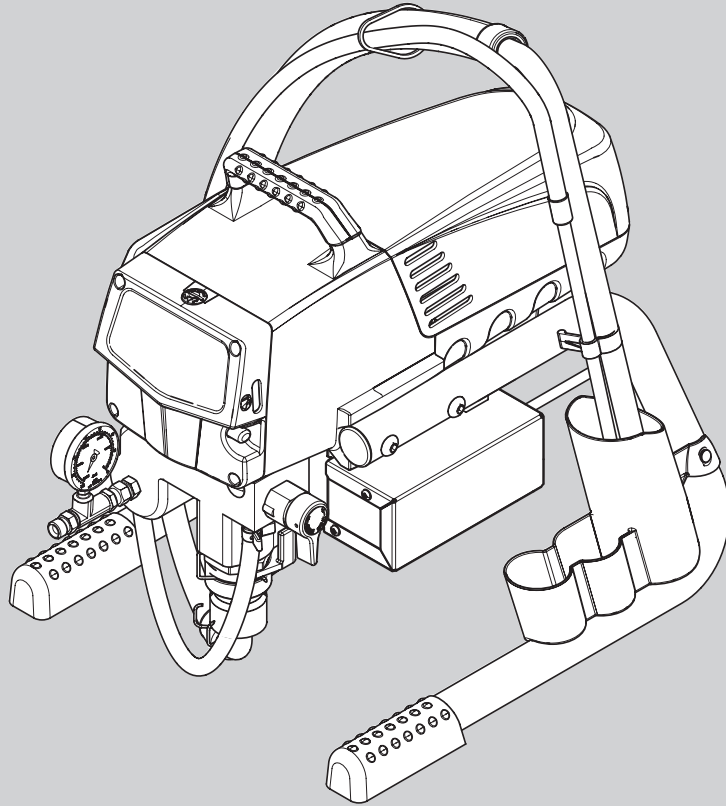

# PROSPRAY 3.21

OWNER'S MANUAL



**MODEL:**  
**0558019**  
**0558046**

wagner-group.com

0218 • Form No. 0558932N

# Warning!

**Attention: Danger of injury by injection!**  
Airless units develop extremely high spraying pressures.

**1**

**Never put your fingers, hands or any other parts of the body into the spray jet!**

**Never point the spray gun at yourself, other persons or animals.  
Never use the spray gun without safety guard.**

**Do not treat a spraying injury as a harmless cut. In case of injury to the skin through coating materials or solvents, consult a doctor immediately for quick and expert treatment. Inform the doctor about the coating material or solvent used.**

**2**

**The operating instructions state that the following points must always be observed before starting up:**

1. Faulty units must not be used.
2. Secure Wagner spray gun using the trigger lock on the trigger.
3. Ensure that the unit is properly earthed.
4. Check allowable operating pressure of high-pressure hose and spray gun.
5. Check all connections for leaks.

**3**

**The instructions regarding regular cleaning and maintenance of the unit must be strictly observed.**

**Before any work is done on the unit or for every break in work the following rules must be observed:**

1. Release the pressure from spray gun and hose.
2. Secure the Wagner spray gun using the trigger lock on the trigger.
3. Switch off unit.

# Be safety conscious!

<b>1</b>	<b>SAFETY REGULATIONS FOR AIRLESS SPRAYING</b>	<b>4</b>	<b>8</b>	<b>CLEANING THE UNIT (SHUTTING DOWN)</b>	<b>17</b>
1.1	Explanation of symbols used	4	8.1	Cleaning unit from outside	17
1.2	Electric safety	8	8.2	Suction filter	17
1.3	Electrostatic charging (formation of sparks or flames)	8	8.3	Cleaning the high-pressure filter	18
<b>2</b>	<b>GENERAL VIEW OF APPLICATION</b>	<b>9</b>	8.4	Cleaning Airless spray gun	18
2.1	Application	9	<b>9</b>	<b>REMEDY IN CASE OF FAULTS</b>	<b>19</b>
2.2	Coating materials	9	<b>10</b>	<b>SERVICING</b>	<b>20</b>
<b>3</b>	<b>DESCRIPTION OF UNIT</b>	<b>10</b>	10.1	General servicing	20
3.1	Airless process	10	10.2	High-pressure hose	20
3.2	Functioning of the unit	10	<b>11</b>	<b>REPAIRS AT THE UNIT</b>	<b>20</b>
3.3	Legend for explanatory diagram PS 3.21	11	11.1	Relief valve	20
3.4	Explanatory diagram PS 3.21	11	11.2	Inlet and outlet valve	21
3.5	Technical data	12	11.3	Packings	22
3.6	Transportation in vehicle	12	11.4	PS 3.21 connection diagram	23
<b>4</b>	<b>STARTING OPERATION</b>	<b>12</b>	<b>12</b>	<b>APPENDIX</b>	<b>24</b>
4.1	High-pressure hose, spray gun and separating oil	12	12.1	Selection of tip	24
4.2	Control panel indicators	13	12.2	Servicing and cleaning of Airless hard-metal tips	24
4.3	Pressure control knob settings	13	12.3	Spray gun accessories	25
4.4	Connection to the mains network	14	12.4	Airless tip table	26/27
4.5	Cleaning preserving agent when starting-up of operation initially	14	12.5	TempSpray	28
4.6	Taking the unit into operation with coating material	14	12.6	Pump-Runner	29
<b>5</b>	<b>SPRAYING TECHNIQUE</b>	<b>15</b>	<b>ACCESSORIES FOR PROSPRAY 3.21</b> <b>30/31</b>		
<b>6</b>	<b>HANDLING THE HIGH-PRESSURE HOSE</b>	<b>16</b>	Spare parts list for main assembly		
<b>7</b>	<b>INTERRUPTION OF WORK</b>	<b>16</b>	Spare parts list for the fluid section		
			Spare parts list for drive assembly		
			Spare parts list of stand		
			Spare parts list for suction system		
			<b>IMPORTANT NOTES ON PRODUCT LIABILITY</b> <b>37</b>		
			<b>3+2 YEARS GUARANTEE FOR PROFESSIONAL FINISHING</b> <b>37</b>		
			<b>SALES AND SERVICE COMPANIES</b> <b>39/40</b>		

# 1 SAFETY REGULATIONS FOR AIRLESS SPRAYING

## 1.1 EXPLANATION OF SYMBOLS USED

This manual contains information that must be read and understood before using the equipment. When you come to an area that has one of the following symbols, pay particular attention and make certain to heed the safeguard.



→ This symbol indicates a potential hazard that may cause serious injury or loss of life. Important safety information will follow.



→ This symbol indicates a potential hazard to you or to the equipment. Important information that tells how to prevent damage to the equipment or how to avoid causes of minor injuries will follow.



→ Danger of skin injection



→ Danger of fire from solvent and paint fumes



→ Danger of explosion from solvent, paint fumes and incompatible materials



→ Danger of injury from inhalation of harmful vapors



→ Notes give important information which should be given special attention.



### HAZARD: INJECTION INJURY

Attention: Danger of injury by injection! A high pressure stream produced by this equipment can pierce the skin and underlying tissues, leading to serious injury and possible amputation.

Do not treat a spraying injury as a harmless cut. In case of injury to the skin through coating materials or solvents, consult a doctor immediately for quick and expert treatment. Inform the doctor about the coating material or solvent used.

### PREVENTION:

- NEVER aim the gun at any part of the body.
- NEVER allow any part of the body to touch the fluid stream. DO NOT allow body to touch a leak in the fluid hose.
- NEVER put your hand in front of the gun. Gloves will not provide protection against an injection injury.
- ALWAYS lock the gun trigger, shut the fluid pump off and release all pressure before servicing, cleaning the tip guard, changing tips, or leaving unattended. Pressure will not be released by turning off the engine. The PRIME/SPRAY valve or pressure bleed valve must be turned to their appropriate positions to relieve system pressure.
- ALWAYS keep tip guard in place while spraying. The tip guard provides some protection but is mainly a warning device.
- ALWAYS remove the spray tip before flushing or cleaning the system.
- NEVER use a spray gun without a working trigger lock and trigger guard in place.

- All accessories must be rated at or above the maximum operating pressure range of the sprayer. This includes spray tips, guns, extensions, and hose.

**HAZARD: HIGH PRESSURE HOSE**

The paint hose can develop leaks from wear, kinking and abuse. A leak can inject material into the skin. Inspect the hose before each use.

---

---

**PREVENTION:**

- Avoid sharp bending or kinking of the high-pressure hose. The smallest bending radius amounts to about 20 cm.
- Do not drive over the high-pressure hose. Protect against sharp objects and edges.
- Replace any damaged high-pressure hose immediately.
- Never repair defective high-pressure hoses yourself!
- Electrostatic charging of spray guns and the high-pressure hose is discharged through the high-pressure hose. For this reason the electric resistance between the connections of the high-pressure hose must be equal to or lower than 1MΩ.
- For reasons of function, safety and durability use only original Wagner high-pressure hoses.
- Before each use, check all hoses for cuts, leaks, abrasion or bulging of cover. Check for damage or movement of couplings. Immediately replace the hose if any of these conditions exist. Never repair a paint hose. Replace it with another earthed high-pressure hose.
- Make sure power cord, air hose and spray hoses are routed in such a manner to minimize slip, trip and fall hazard.



---



---

**HAZARD: EXPLOSION OR FIRE**

Flammable vapors, such as solvent and paint vapors, in work area can ignite or explode.

---



---

**PREVENTION:**

- Do not use materials with a flashpoint below 38° C (100° F). Flashpoint is the temperature at which a fluid can produce enough vapors to ignite.
- Do not use the unit in work places which are covered by the explosion protection regulations.
- Provide extensive exhaust and fresh air introduction to keep the air within the spray area free from accumulation of flammable vapors.
- Avoid all ignition sources such as static electricity sparks, electrical appliances, flames, pilot lights, hot objects, and sparks from connecting and disconnecting power cords or working light switches.
- Do not smoke in spray area.
- Place sprayer sufficient distance from the spray object in a well ventilated area (add more hose if necessary). Flammable vapors are often heavier than air. Floor area must be extremely well ventilated. The pump contains arcing parts that emit sparks and can ignite vapors.
- The equipment and objects in and around the spray area must be properly grounded to prevent static sparks.
- Use only conductive or earthed high pressure fluid hose. Gun must be earthed through hose connections.
- Power cord must be connected to a grounded circuit (electric units only).
- Always flush unit into separate metal container, at low pump pressure, with spray tip removed. Hold gun firmly against side of container to ground container and prevent static sparks.
- Follow material and solvent manufacturer's warnings and instructions. Be familiar with the coating material's MSDS sheet and technical information to ensure safe use.
- Use lowest possible pressure to flush equipment.
- When cleaning the unit with solvents, the solvent should never be sprayed or pumped back into a container with a small opening (bung hole). An explosive gas/air mixture can arise. The container must be earthed.
- Do not use a paint or solvent containing halogenated hydrocarbons. Such as chlorine, bleach, mildewcide, methylene chloride and trichloroethane. They are not compatible with aluminum. Contact the coating supplier about compatibility of material with aluminum.

**HAZARD: HAZARDOUS VAPORS**

Paints, solvents, and other materials can be harmful if inhaled or come in contact with body. Vapors can cause severe nausea, fainting, or poisoning.

**PREVENTION:**

- Wear respiratory protection when spraying. Read all instructions supplied with the mask to be sure it will provide the necessary protection.
- All local regulations regarding protection against hazardous vapors must be observed.
- Wear protective eyewear.
- Protective clothing, gloves and possibly skin protection cream are necessary for the protection of the skin. Observe the regulations of the manufacturer concerning coating materials, solvents and cleaning agents in preparation, processing and cleaning units.

**HAZARD: GENERAL**

This product can cause severe injury or property damage.

**PREVENTION:**

- Follow all appropriate local, state, and national codes governing ventilation, fire prevention, and operation.
- Pulling the trigger causes a recoil force to the hand that is holding the spray gun. The recoil force of the spray gun is particularly powerful when the tip has been removed and a high pressure has been set on the airless pump. When cleaning without a spray tip, set the pressure control knob to the lowest pressure.
- Use only manufacturer authorized parts. User assumes all risks and liabilities when using parts that do not meet the minimum specifications and safety devices of the pump manufacturer.
- ALWAYS follow the material manufacturer's instructions for safe handling of paint and solvents.
- Clean up all material and solvent spills immediately to prevent slip hazard.
- Wear ear protection. This unit can produce noise levels above 85 dB(A).
- Never leave this equipment unattended. Keep away from children or anyone not familiar with the operation of airless equipment.
- Do not spray on windy days.
- The device and all related liquids (i.e. hydraulic oil) must be disposed of in an environmentally friendly way.

## 1.2 ELECTRIC SAFETY

Electric models must be earthed. In the event of an electrical short circuit, earthing reduces the risk of electric shock by providing an escape wire for the electric current. This product is equipped with a cord having an earthing wire with an appropriate earthing plug. Connection to the mains only through a special feed point, e.g. through an error protection installation with  $I_{NF} < 30 \text{ mA}$ .



**DANGER** — Work or repairs at the electrical equipment may only be carried out by a skilled electrician. No liability is assumed for incorrect installation. Switch the unit off. Before all repair work, unplug the power plug from the outlet.

Danger of short-circuits caused by water ingressing into the electrical equipment. Never spray down the unit with high-pressure or high-pressure steam cleaners.

### **WORK OR REPAIRS AT THE ELECTRICAL EQUIPMENT:**

These may only be carried out by a skilled electrician. No liability is assumed for incorrect installation.

## 1.3 ELECTROSTATIC CHARGING (FORMATION OF SPARKS OR FLAMES)



Electrostatic charging of the unit may occur during spraying due to the flow speed of the coating material. These can cause sparks and flames upon discharge. The unit must therefore always be earthed via the electrical system. The unit must be connected to an appropriately-grounded safety outlet.

An electrostatic charging of spray guns and the high-pressure hose is discharged through the high-pressure hose. For this reason the electric resistance between the connections of the high-pressure hose must be equal to or lower than  $1 \text{ M}\Omega$ .



## 2 GENERAL VIEW OF APPLICATION

### 2.1 APPLICATION

 = Recommended  = Not-recommended

Materials	Object Size	Model						
		PS 3.21	PS 3.23	PS 3.25	PS 3.29	PS 3.31	PS 3.34	PS 3.39
Release agents, oils, undercoats, primers, fillers, synthetic resin-based paints, acrylic paints recommended nozzle size: FineFinish 0.008" - 0.014"	up to 200 m <sup>2</sup>							
	200 m <sup>2</sup> - 800 m <sup>2</sup>							
	more than 800 m <sup>2</sup>							
Emulsion paints, latex paints recommended nozzle size: 0.017" - 0.027"	up to 200 m <sup>2</sup>							
	200 m <sup>2</sup> - 800 m <sup>2</sup>							
	more than 800 m <sup>2</sup>							
Anti-corrosive agents, flame retardants, fabric adhesive recommended nozzle size: 0.021" - 0.031"	up to 200 m <sup>2</sup>							
	200 m <sup>2</sup> - 800 m <sup>2</sup>							
	more than 800 m <sup>2</sup>							
Airless-scrapers recommended nozzle size: 0.027" - 0.039"	up to 200 m <sup>2</sup>							
	200 m <sup>2</sup> - 800 m <sup>2</sup>							
	more than 800 m <sup>2</sup>							

### 2.2 COATING MATERIALS

#### PROCESSIBLE COATING MATERIALS

i

Pay attention to the Airless quality of the coating materials to be processed.

Dilutable lacquers and paints or those containing solvents, two-component coating materials, dispersions, latex paints, release agents, oils, undercoats, primers, and fillers.

No other materials should be used for spraying without Wagner's approval.

#### FILTERING

Despite suction filter and insertion filter in the spray gun, filtering of the coating material is generally advisable.

Stir coating material before commencement of work.

i

Attention: Make sure, when stirring up with motor-driven agitators that no air bubbles are stirred in. Air bubbles disturb when spraying and can, in fact, lead to interruption of operation.

#### VISCOSITY

With this unit it is possible to process highly viscous coating materials of up to around 20.000 MPa·s.

If highly viscous coating materials cannot be taken in by suction, they must be diluted in accordance with the manufacturer's instructions.

#### TWO-COMPONENT COATING MATERIAL

The appropriate processing time must be adhered to exactly. Within this time rinse through and clean the unit meticulously with the appropriate cleaning materials.

#### COATING MATERIALS WITH SHARP-EDGED ADDITIONAL MATERIALS

These have a strong wear and tear effect on valves, high-pressure hose, spray gun and tip. The durability of these parts can be reduced appreciably through this.

## 3 DESCRIPTION OF UNIT

### 3.1 AIRLESS PROCESS

The main areas of application are thick layers of highly viscous coating material for large areas and a high consumption of material.

A piston pump takes in the coating material by suction and conveys it to the tip. Pressed through the tip at a pressure of up to a maximum of 221 bar (22.1 MPa), the coating material is atomised. This high pressure has the effect of micro fine atomisation of the coating material.

As no air is used in this process, it is described as an AIRLESS process.

This method of spraying has the advantages of finest atomisation, cloudless operation and a smooth, bubble-free surface. As well as these, the advantages of the speed of work and convenience must be mentioned.

### 3.2 FUNCTIONING OF THE UNIT

In the following there is a short description of the technical construction for better understanding of the function.

Wagner PS 3.21 units are electrically driven high-pressure spraying units.

A gear unit transfers the driving force to a crankshaft. The crankshaft moves the pistons of the material feed pump up and down.

The inlet valve is opened automatically by the upwards movement of the piston. The outlet valve is opened when the piston moves downward.

The coating material flows under high pressure through the high-pressure hose to the spray gun. When the coating material exits from the tip it atomizes.

The pressure control knob controls the volume and the operating pressure of the coating material.

### 3.3 LEGEND FOR EXPLANATORY DIAGRAM PS 3.21

- |                       |   |
|-----------------------|---|
| 1. Spray gun          | 9. Oil button   |
| 2. High-pressure hose | 10. Oil level gauge   |
| 3. Return hose        | 11. ON/OFF switch   |
| 4. Suction hose       | 12. Control panel indicators  |
| 5. Frame              | 13. Pressure control knob   |
| 6. Drip cup           | 14. Oil cup for EasyGlide (EasyGlide prevents increased wear of the packings) |
| 7. Power cord         | 15. Pusher stem   |
| 8. Relief valve       | 16. Manometer   |
- Lever position vertical – PRIME (↻ circulation)  
Lever position horizontal – SPRAY (→)

### 3.4 EXPLANATORY DIAGRAM PS 3.21

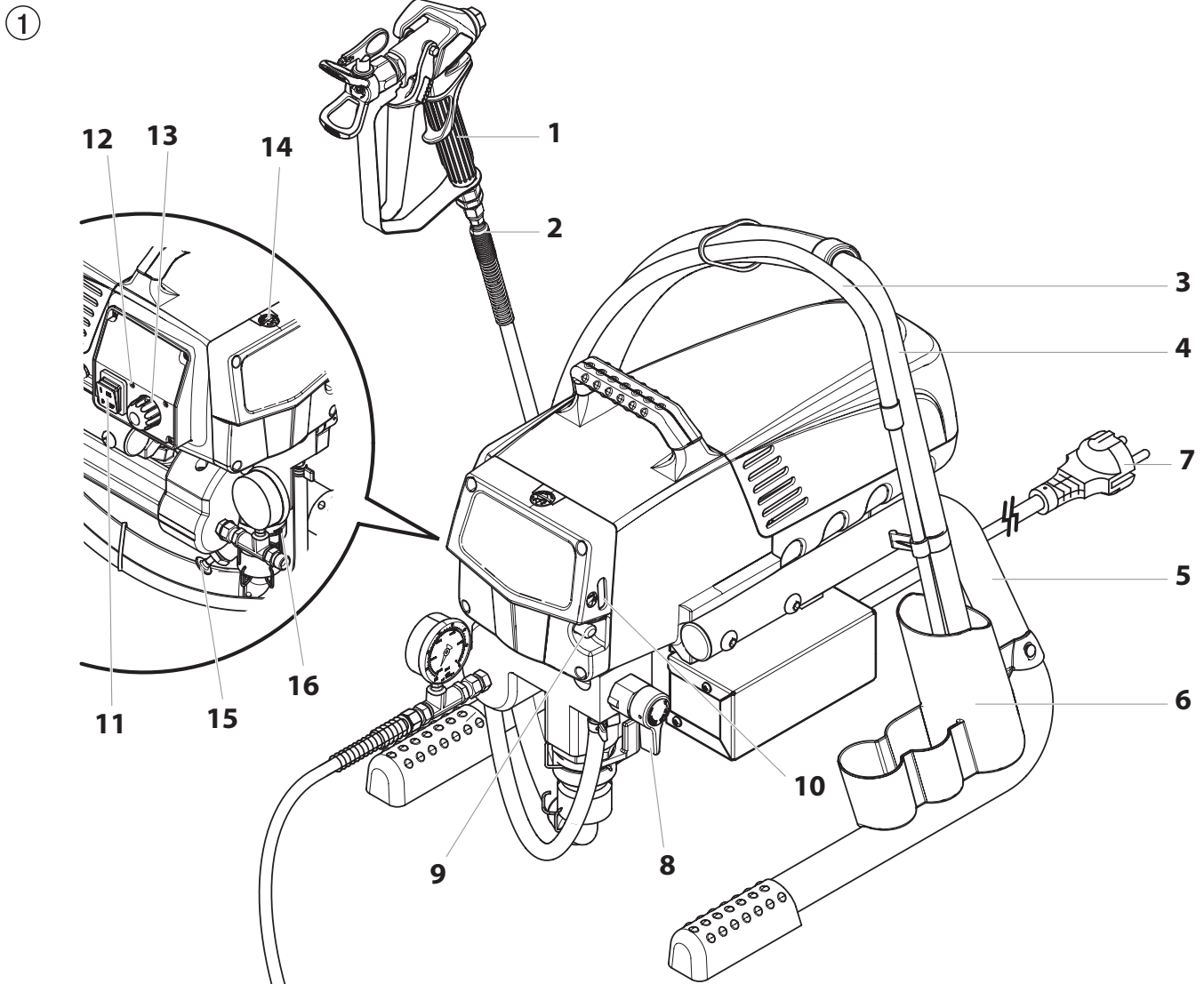

### 3.5 TECHNICAL DATA

<b>Voltage</b>	100~120 VAC, 50/60 Hz
<b>Max. current consumption</b>	9.0 A
<b>Power Cord</b>	3 x 1.5 mm <sup>2</sup> – 6 m
<b>Acceptance capacity</b>	900 Watt
<b>Max. operating pressure</b>	221 bar (22.1 MPa)
<b>Volume flow at 12 MPa (120 bar) with water</b>	2.0 l/min
<b>Max tip size</b>	0.023 inch – 0.58 mm
<b>Max. temperature of the coating material</b>	43°C
<b>Max viscosity</b>	20.000 MPa·s
<b>Weight</b>	17.9 kg
<b>Special high-pressure hose</b>	DN 6 mm, 15 m, connection thread M 16 x 1.5
<b>Dimensions (L X W X H)</b>	437 x 363 x 416 mm
<b>Altitude</b>	This equipment will operate correctly up to 2000 m above mean sea level
<b>Vibration</b>	Spray gun does not exceed 2.5m/s <sup>2</sup>
<b>Max sound pressure level</b>	80 dB*

\* Place of measurement: 1 m distance from unit and 1.60m above floor, 12 MPa (120 bar) operating pressure, reverberant floor

### 3.6 TRANSPORTATION IN VEHICLE

Secure the unit with a suitable fastening.

## 4 STARTING OPERATION

### 4.1 HIGH-PRESSURE HOSE, SPRAY GUN AND SEPARATING OIL

1. Screw the pressure gauge (1) to the coating material outlet (Fig. 2, Item 2).
2. Screw the high-pressure hose (3) to the coating material outlet (Fig. 2, Item 4).
3. Screw the spray gun (5) with the selected tip onto the high-pressure hose.
4. Tighten the union nuts at the high-pressure hoses firmly so that coating material does not leak.

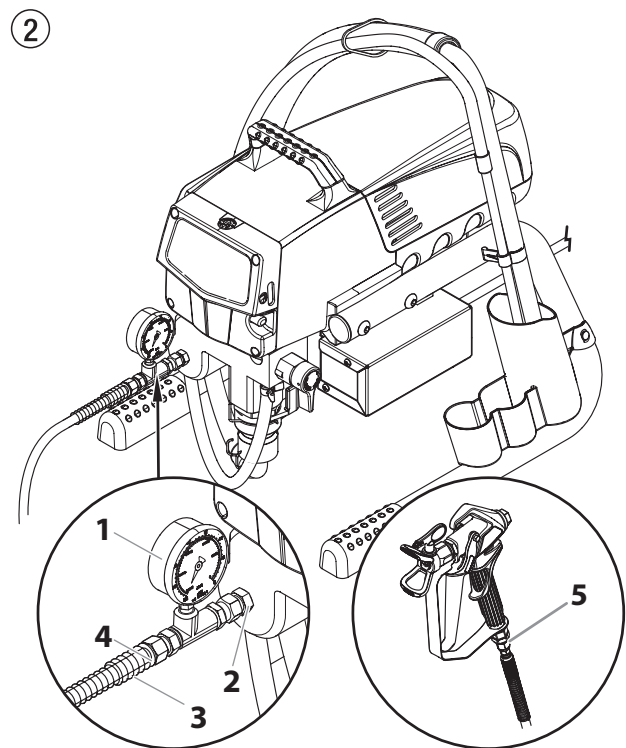

5. Remove the oil cup cap with a straight-slot screwdriver.
6. Fill the oil cup with EasyGlide (Fig. 3) until the oil gauge (6) is showing that it is full.



Attention

EasyGlide prevents increased wear and tear to the packings.

7. Replace oil cup cap.
8. Press oil button 2-5 times to prime the oiler. Press once for every eight hours of usage to lubricate the fluid section.
9. Fully depress the pusher stem to make sure the inlet ball is free.

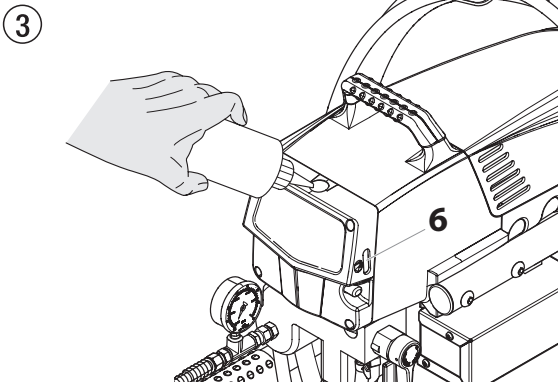

## 4.2 CONTROL PANEL INDICATORS

The following is a description of the control panel indicators.

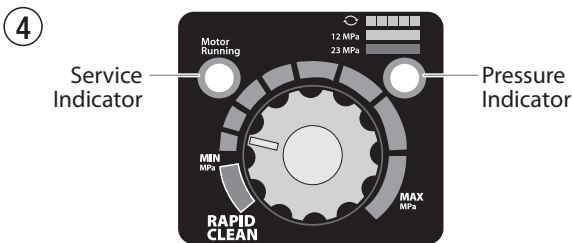

### SERVICE INDICATOR

The Service indicator is on when the motor is commanded to run. This indicator is used by service centers to troubleshoot motor problems.

### PRESSURE INDICATOR

The pressure indicator shows the current operating pressure of the sprayer. It has three different indications: blinking yellow, solid yellow, and solid green.

#### Blinking Yellow

When the pressure indicator is blinking yellow, the sprayer is operating between 0 and 1.4 MPa (14 bar). A blinking yellow pressure indicator means:

- The sprayer is plugged in and turned "ON"
- The sprayer is at priming pressure (little or no pressure)
- It is safe to move the relief valve between positions
- It is safe to change or replace the spray tip



If the pressure indicator begins blinking yellow when the pressure control knob is set at a higher pressure and the relief valve is in the SPRAY position, either the spray tip is worn or the sprayer is in need of service/repair.

#### Solid Yellow

When the pressure indicator is solid yellow, the sprayer is operating between 1.4 MPa (14 bar) and 12 MPa (120 bar). A solid yellow pressure indicator means:

- The sprayer is at the proper pressure setting for spraying stain, lacquer, varnish, and multi-colors

#### Solid Green

When the pressure indicator is solid green, the sprayer is operating between 12 MPa (120 bar) and 23 MPa (230 bar). A solid green pressure indicator means:

- The sprayer is at the proper pressure setting for spraying oil-based and latex house paints
- The sprayer is operating at peak performance at a high pressure setting
- If the pressure indicator goes to solid yellow when the pressure is set so that it starts at solid green, it indicates one of the following:
  - a. **Tip Wear Indicator** — when spraying with latex or at high pressure the solid yellow appears. This means the tip is worn and needs to be replaced.
  - b. **Tip Too Large** — when a tip that is too large for the sprayer is put in the gun, the pressure indicator will turn from solid green to solid yellow.
  - c. **Fluid Section Wear** — if a solid yellow pressure indicator appears when using a new tip and the pressure is set at maximum, service may be required (worn packings, worn piston, stuck valve, etc...).

## 4.3 PRESSURE CONTROL KNOB SETTINGS

1. Minimum pressure setting
2. Black zone – no pressure generation
3. Blue zone – pulsating pressure for cleaning

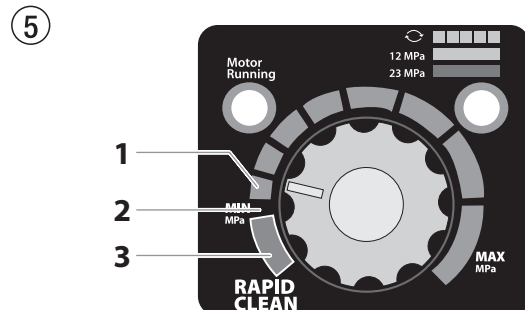

#### 4.4 CONNECTION TO THE MAINS NETWORK



The unit must be connected to an appropriately-grounded safety outlet.

Before connecting the unit to the mains supply, ensure that the line voltage matches that specified on the unit's rating plate.

The connection must be equipped with a residual current protective device with  $INF \leq 30 \text{ mA}$ .



Wagner's accessories program also includes a mobile operator protection device for the electronic supply, which can also be used with other electronic equipment.

#### 4.5 CLEANING PRESERVING AGENT WHEN STARTING-UP OF OPERATION INITIALLY

1. Immerse the suction tube (Fig. 6, Item 2) return hose (1) into a container with a suitable cleaning agent.
2. Turn the pressure control knob counterclockwise (3) to minimum pressure.
3. Open the relief valve (4), valve position PRIME (↻ circulation).
4. Switch the unit (5) ON.
5. Wait until the cleaning agent exudes from the return hose.
6. Close the relief valve, valve position SPRAY (↗ spray).
7. Pull the trigger of the spray gun.
8. Spray the cleaning agent from the unit into an open collecting container.

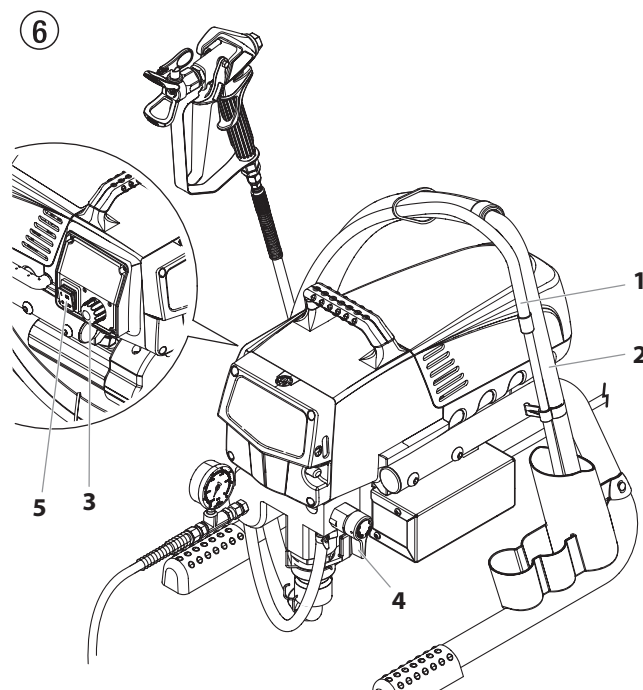

#### 4.6 TAKING THE UNIT INTO OPERATION WITH COATING MATERIAL

1. Immerse the suction tube (Fig. 6, Item 2) and return hose (1) into the coating material container.
2. Turn the pressure control knob counterclockwise (3) to minimum pressure.
3. Open the relief valve (4), valve position PRIME (↻ circulation).
4. Switch the unit (5) ON.
5. Wait until the coating material exudes from the return hose.
6. Close the relief valve, valve position SPRAY (↗ spray).
7. Trigger the spray gun several times and spray into a collecting container until the coating material exits the spray gun without interruption.
8. Increase the pressure by slowly turning up the pressure control knob.

Check the spray pattern and increase the pressure until the atomization is correct.

Always turn the pressure control knob to the lowest setting with good atomization.

9. The unit is ready to spray.

## 5 SPRAYING



Injection hazard. Do not spray without the tip guard in place. NEVER trigger the gun unless the tip is completely turned to either the spray or the unclog position. ALWAYS engage the gun trigger lock before removing, replacing or cleaning tip.

- A)** The key to a good paint job is an even coating over the entire surface. Keep your arm moving at a constant speed and keep the spray gun at a constant distance from the surface. The best spraying distance is 10-12 inches (25 to 30 cm) between the spray tip and the surface.

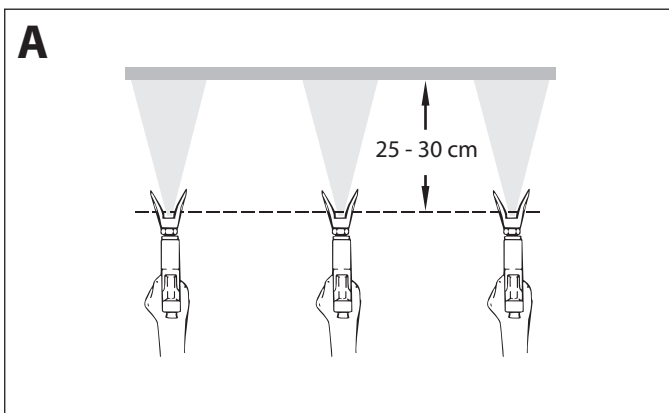

- B)** Keep the spray gun at right angles to the surface. This means moving your entire arm back and forth rather than just flexing your wrist.

Keep the spray gun perpendicular to the surface, otherwise one end of the pattern will be thicker than the other.

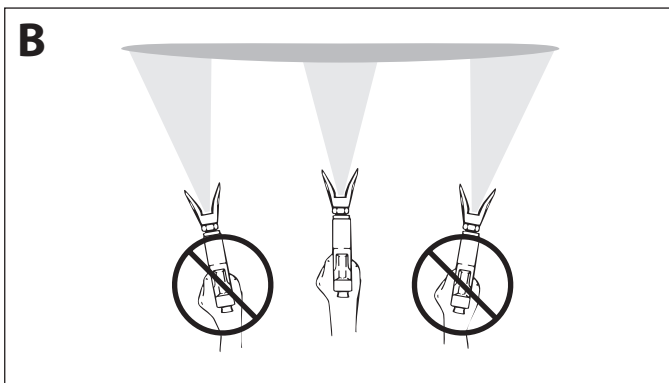

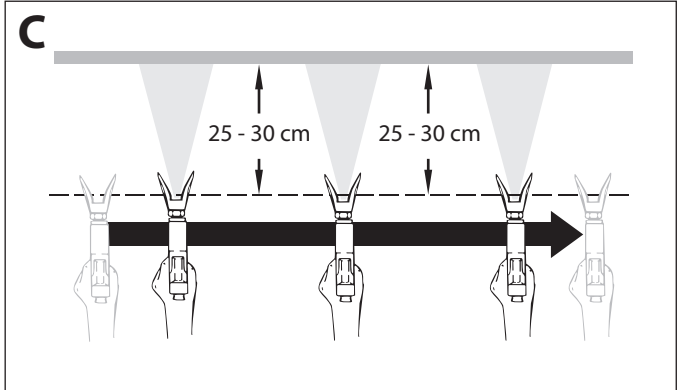

- C)** Trigger gun after starting the stroke. Release the trigger before ending the stroke. The spray gun should be moving when the trigger is pulled and released. Overlap each stroke by about 30%. This will ensure an even coating.



If very sharp edges result or if there are streaks in the spray jet – increase the operating pressure or dilute the coating material.

## 6 HANDLING THE HIGH-PRESSURE HOSE



	The unit is equipped with a high-pressure hose specially suited for piston pumps.
	<p>Danger of injury through leaking high-pressure hose. Replace any damaged high-pressure hose immediately.</p> <p>Never repair defective high-pressure hoses yourself!</p>

The high-pressure hose is to be handled with care. Avoid sharp bends and folds: the smallest bending radius is about 8" (20 cm).

Do not drive over the high-pressure hose. Protect against sharp objects and edges.

Never pull on the high-pressure hose to move the device.

Make sure that the high-pressure hose cannot twist. This can be avoided by using a Wagner spray gun with a swivel joint and a hose system.

	When using the high-pressure hose while working on scaffolding, it is best to always guide the hose along the outside of the scaffolding.
	The risk of damage rises with the age of the high-pressure hose. Wagner recommends replacing high-pressure hoses after 6 years.
	Use only Wagner original-high-pressure hoses in order to ensure functionality, safety and durability.



## 7 INTERRUPTION OF WORK

1. Open the relief valve, valve position PRIME (↻ circulation).
2. Switch the unit OFF.
3. Turn the pressure control knob counterclockwise to minimum pressure.
4. Pull the trigger of the spray gun in order to release the pressure from the high-pressure hose and spray gun.
5. Secure the spray gun, refer to the operating manual of the spray gun.
6. If a standard tip is to be cleaned, see Page 24, Section 12.2.  
If a non-standard tip is installed, proceed according to the relevant operating manual.
7. Depending on the model, leave the suction tube or the suction hose and return hose immersed in the coating material or swivel or immerse it into a corresponding cleaning agent.



 Attention	If fast-drying or two-component coating material is used, ensure that the unit is rinsed with a suitable cleaning agent within the processing time.
--	---



## 8 CLEANING THE UNIT (SHUTTING DOWN)



	A clean state is the best method of ensuring operation without problems. After you have finished spraying, clean the unit. Under no circumstances may any remaining coating material dry and harden in the unit.
	The cleaning agent used for cleaning (only with an ignition point above 38 °C) must be suitable for the coating material used.
	<ul style="list-style-type: none"> <li>• <b>Secure the spray gun</b>, refer to the operating manual of the spray gun.</li> <li>• Clean and remove tip.</li> <li>• For a standard tip, refer to Page 24, Section 12.2.</li> <li>• If a non-standard tip is installed, proceed according to the relevant operating manual.</li> </ul>

1. Remove suction hose from the coating material.
2. Close the relief valve, valve position SPRAY (→ spray).
3. Switch the unit ON.

 Attention	The container must be earthed in case of coating materials which contain solvents.
	Caution! Do not pump or spray into a container with a small opening (bunghole)!

4. Pull the trigger of the spray gun in order to pump the remaining coating material from the suction hose, high-pressure hose and the spray gun into an open container.
5. Immerse suction hose with return hose into a container with a suitable cleaning agent.
6. Turn the pressure control knob counterclockwise to minimum pressure.
7. Open the relief valve, valve position PRIME (↻ circulation).
8. Pump a suitable cleaning agent in the circuit for a few minutes.
9. Close the relief valve, valve position SPRAY (→ spray).
10. Pull the trigger of the spray gun.
11. Pump the remaining cleaning agent into an open container until the unit is empty.
12. Switch the unit OFF.

### 8.1 CLEANING UNIT FROM OUTSIDE

	First of all pull out mains plug from socket.
 Attention	<p>Danger of short circuit through penetrating water!</p> <p>Never spray down the unit with high-pressure or high-pressure steam cleaners.</p> <p>Do not put the high-pressure hose into solvents. Use only a wet cloth to wipe down the outside of the hose.</p>

Wipe down unit externally with a cloth which has been immersed in a suitable cleaning agent.

### 8.2 SUCTION FILTER

	A clean suction filter always guarantees maximum feed quantity, constant spraying pressure and problem-free functioning of the unit.
---	--

1. Screw off the filter (Fig. 7) from suction tube.
2. Clean or replace the filter.

Carry out cleaning with a hard brush and an appropriate cleaning agent.

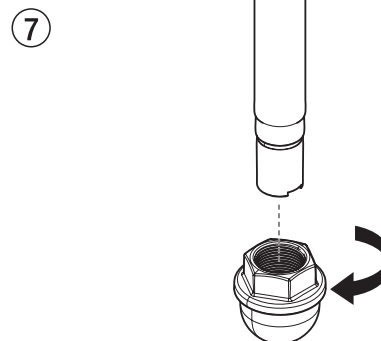

### 8.3 CLEANING THE HIGH-PRESSURE FILTER



Clean the filter cartridge regularly. A soiled or clogged high-pressure filter can cause a poor spray pattern or a clogged tip.

1. Turn the pressure control knob counterclockwise to minimum pressure.
2. Open the relief valve, valve position PRIME (↻ circulation).
3. Switch the unit OFF.



Unplug the power plug from the outlet.

4. Unscrew the filter housing (Fig. 8, Item 1) with a strap wrench.
5. Turning clockwise, unscrew the filter (2) from the pump manifold (3).
6. Clean all the parts with the corresponding cleaning agent. If necessary, replace the filter cartridge.
7. Check the O-ring (4), replace it if necessary.
8. Turning counterclockwise, screw the new or cleaned filter into the pump manifold.
9. Screw in filter housing (1) and tighten it as far as possible with the strap wrench.

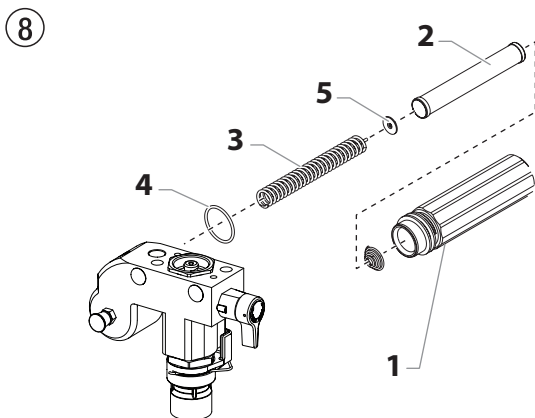

### 8.4 CLEANING AIRLESS SPRAY GUN



Clean the spray gun after each use.

1. Rinse airless spray gun with an appropriate cleaning agent.
2. Clean tip thoroughly with appropriate cleaning agent so that no coating material residue remains.
3. Thoroughly clean the outside of the airless spray gun.

#### INTAKE FILTER IN AIRLESS SPRAY GUN (FIG. 9)

1. Unclip the top of the trigger guard (1) from the gun head.
2. Using the bottom of the trigger guard as a wrench, loosen and remove the handle assembly (2) from the gun head.
3. Pull the old filter (3) out of the gun head. Clean or replace.
4. Slide the new filter, tapered end first, into the gun head.
5. Thread the handle assembly into the gun head. Tighten with the trigger wrench.
6. Snap the trigger guard back onto the gun head.

9

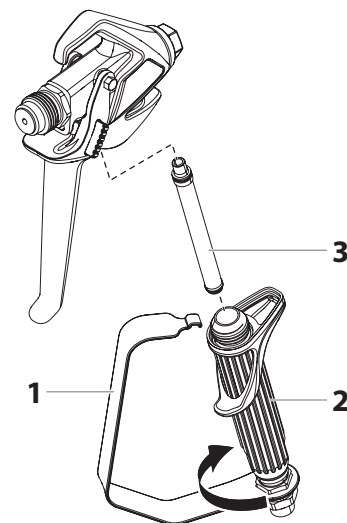

## 9 REMEDY IN CASE OF FAULTS

Type of malfunction	Possible cause	Measures for eliminating the malfunction
A. Unit does not start _____	<ol style="list-style-type: none"> <li>1. No voltage applied.</li> <li>2. Pressure setting too low.</li> <li>3. ON/OFF switch defective.</li> </ol>	<ol style="list-style-type: none"> <li>1. Check voltage supply.</li> <li>2. Turn up pressure control knob.</li> <li>3. Replace.</li> </ol>
B. Unit does not draw in material _____	<ol style="list-style-type: none"> <li>1. Relief valve is set to SPRAY (☞ spray).</li> <li>2. Filter projects over the fluid level and sucks air.</li> <li>3. Filter clogged.</li> <li>4. Suction hose/suction tube is loose, i.e. the unit is sucking in outside air.</li> </ol>	<ol style="list-style-type: none"> <li>1. Set relief valve to PRIME (☉ circulation).</li> <li>2. Refill the coating material.</li> <li>3. Clean or replace the filter.</li> <li>4. Clean connecting points. Replace O-rings if necessary. Secure suction hose with retaining clip.</li> </ol>
C. Unit draws in material, but the pressure does not build up _____	<ol style="list-style-type: none"> <li>1. Tip heavily worn.</li> <li>2. Tip too large.</li> <li>3. Pressure setting too low.</li> <li>4. Filter clogged.</li> <li>5. Coating material flows through the return hose when the relief valve is in the SPRAY (☞ spray) position.</li> <li>6. Packings sticky or worn.</li> <li>7. Valve balls worn.</li> <li>8. Valve seats worn.</li> </ol>	<ol style="list-style-type: none"> <li>1. Replace</li> <li>2. Replace tip.</li> <li>3. Turn pressure control knob clockwise to increase.</li> <li>4. Clean or replace the filter.</li> <li>5. Remove and clean or replace relief valve.</li> <li>6. Remove and clean or replace packings.</li> <li>7. Remove and replace valve balls.</li> <li>8. Remove and replace valve seats.</li> </ol>
D. Coating material exits at the top of the fluid section _____	<ol style="list-style-type: none"> <li>1. Upper packing is worn.</li> <li>2. Piston is worn.</li> </ol>	<ol style="list-style-type: none"> <li>1. Remove and replace packing.</li> <li>2. Remove and replace piston.</li> </ol>
E. Increased pulsation at the spray gun _____	<ol style="list-style-type: none"> <li>1. Incorrect high-pressure hose type.</li> <li>2. Tip worn or too large.</li> <li>3. Pressure too high.</li> </ol>	<ol style="list-style-type: none"> <li>1. Only use WAGNER original-high-pressure hoses in order to ensure functionality, safety and durability.</li> <li>2. Replace tip.</li> <li>3. Turn pressure control knob to a lower number.</li> </ol>
F. Poor spray pattern _____	<ol style="list-style-type: none"> <li>1. Tip is too large for the coating material which is to be sprayed.</li> <li>2. Pressure setting incorrect.</li> <li>3. Volume too low.</li> <li>4. Coating material viscosity too high.</li> </ol>	<ol style="list-style-type: none"> <li>1. Replace tip.</li> <li>2. Turn pressure control knob until a satisfactory spraying pattern is achieved.</li> <li>3. Clean or replace all filters.</li> <li>4. Thin out according to the manufacturer's instructions.</li> </ol>
G. Unit loses power _____	<ol style="list-style-type: none"> <li>1. Pressure setting too low.</li> </ol>	<ol style="list-style-type: none"> <li>1. Turn pressure control knob clockwise to increase.</li> </ol>
H. Pump over-pressurizes and will not shut off. _____	<ol style="list-style-type: none"> <li>1. Pressure switch defective.</li> <li>2. Transducer defective.</li> </ol>	<ol style="list-style-type: none"> <li>1. Take unit to a Wagner authorized service center.</li> <li>2. Take unit to a Wagner authorized service center.</li> </ol>

## 10 SERVICING

### 10.1 GENERAL SERVICING

Servicing of the unit should be carried out once annually by the WAGNER service.

1. Check high-pressure hoses, device connecting line and plug for damage.
2. Check the inlet valve, outlet valve and filter for wear.

### 10.2 HIGH-PRESSURE HOSE

Inspect the high-pressure hose visually for any notches or bulges, in particular at the transition in the fittings. It must be possible to turn the union nuts freely.



The risk of damage rises with the age of the high-pressure hose. Wagner recommends replacing high-pressure hoses after 6 years.

## 11 REPAIRS AT THE UNIT



Switch the unit OFF.

Before all repair work: Unplug the power plug from the outlet.



Make sure to check for grounding continuity after service is performed on any electrical components.

Use an ohmmeter to determine that there is continuity between accessible dead-metal parts of the product and the grounding blade of the attachment plug.

### 11.1 RELIEF VALVE



The valve housing (4) should not be repaired. If worn, it should always be replaced with a new one.

1. Use a drift punch of 2 mm to remove the grooved pin (Fig. 10, Item 1) from the relief valve handle (2).
2. Remove the relief valve handle (2) and cam base (3).
3. Using a wrench, remove the valve housing (4) from the pump manifold (6).
4. Ensure that the seal (5) is seated correctly, then screw the new valve housing (4) completely into the pump manifold (6). Tighten securely with a wrench.
5. Align the cam base (3) with the hole in the pump manifold (6). Lubricate the cam base with grease and slide on the cam base.
6. Bring the hole in the valve shaft (7) and in the relief valve handle (2) into alignment.
7. Insert the grooved pin (1) to secure the relief valve handle in position.

⑩

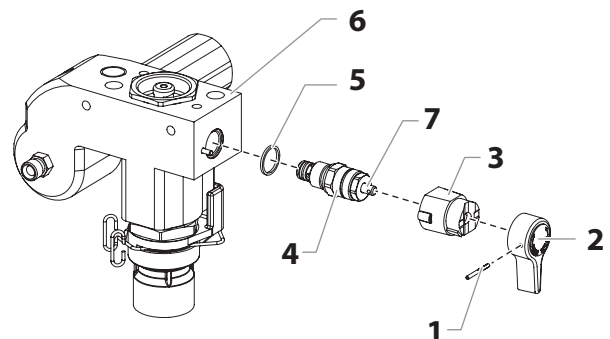

## 11.2 INLET AND OUTLET VALVE

1. Remove the four screws in the front cover and then remove the front cover.
2. Switch the unit ON and then OFF so that the piston rod is positioned in the lower stroke position.



Danger of crushing - do not reach with the fingers or tool between the moving parts.

3. Unplug the power plug from the outlet.
4. Remove the retaining clip from the connecting bend at the suction hose and pull off the suction hose.
5. Screw off the return hose.
6. Swivel the unit 90° to the rear in order to work more easily on the material feed pump.
7. Remove the pusher stem clip and slide the pusher stem housing (7) from the inlet valve housing (1).
8. Unscrew the inlet valve housing (Fig. 11, Item 1) from the pump manifold.
9. Remove the lower seal (2), lower ball guide (3), inlet valve ball (4), inlet valve seat (5) and O-ring (6).
10. Clean all the parts with the corresponding cleaning agent.

Check the inlet valve housing (1), inlet valve seat (5) and inlet valve ball (4) for wear and replace the parts if necessary. If the worn inlet valve seat (5) is unused on one side, install it the other way round.

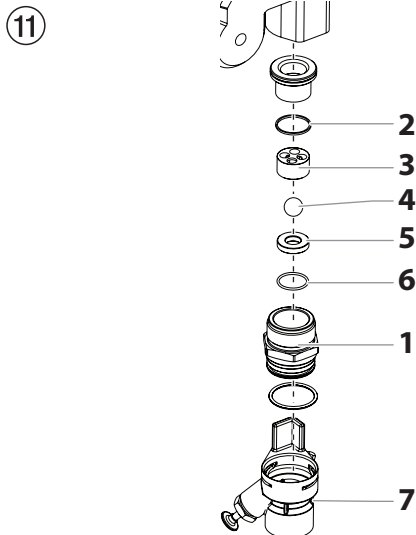

11. Unscrew outlet valve housing (Fig. 12, Item 8) from the piston (9) with adjusting wrench.
12. Remove the upper ball cage (11), crush washer (10), outlet valve ball (12), and outlet valve seat (13).
13. Clean all the parts with the corresponding cleaning agent. Check outlet valve housing (8), outlet valve seat (13), outlet valve ball (12), crush washer (10), and upper ball cage (11) for wear and replace parts if necessary. If the worn outlet valve seat (13) is unused on one side, install it the other way round.
14. Carry out installation in the reverse order. Lubricate O-ring (Fig. 11, Item 6) with machine grease and ensure proper seating in the inlet valve housing (Fig. 11, Item 1).

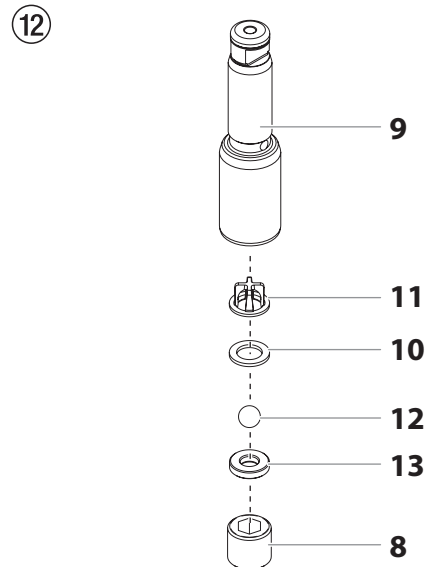

### 11.3 PACKINGS

1. Remove inlet valve housing in accordance with the steps in Chapter 11.2, Page 21.
2. It is not necessary to remove the outlet valve.
3. Unscrew both cylinder head screws (Fig. 13, Item 1) from the pump manifold (2) with a 3/8 inch hexagon socket head wrench.
4. Slide the pump manifold (2) and piston (3) forward until the piston is out of the T-slot (9) on the slider assembly (4).
5. Push piston (3) downward out of the pump manifold (2).
6. Unscrew retainer nut (5) from the pump manifold (2) and remove piston guide (6).
7. Remove upper packing (7) and lower packing (8) from the pump manifold (2).

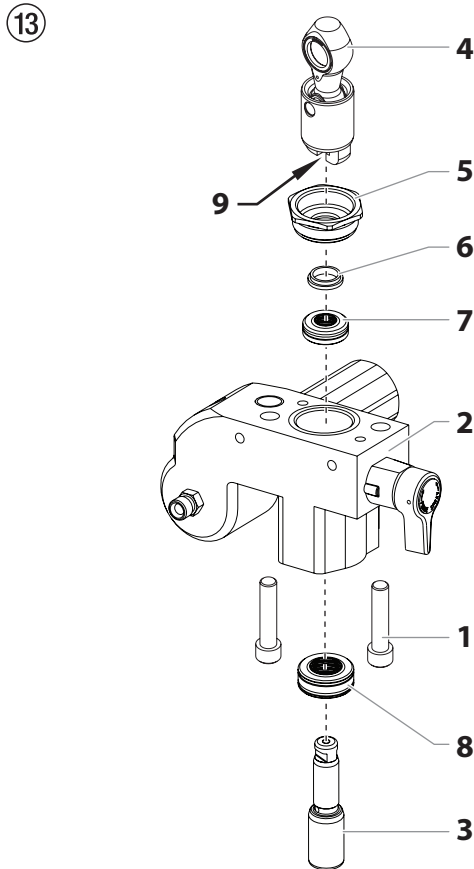

8. Clean pump manifold (2).
9. Lubricate upper packing (7) and lower packing (8) with machine grease.
10. Insert upper packing (Fig. 14) with O-ring (1) and protruding lip (2) downward.

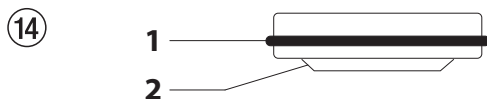

11. Insert lower packing (Fig. 15) with the beveled edge (1) facing upward.

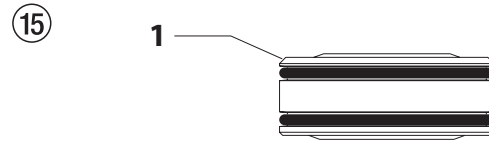

12. Insert piston guide (Fig. 13, Item 6) into the retainer nut (5). Screw retainer nut (5) into the pump manifold (2) and tighten by hand.
13. Push installation tool (included with the replacement packings) for the piston (3) from above onto the piston.
14. Lubricate installation tool and piston (3) with machine grease.
15. Guide piston (3) through the lower packings (8) into the pump manifold (2) from below. Using a rubber mallet, lightly tap the piston (3) from below until it can be seen above the pump manifold.
16. Remove installation tool from piston (3).
17. Carefully tighten retainer nut (5) with adjusting wrench.
18. Slide the top of the piston (3) into the T-slot (9) on the slider assembly (4).
19. Position the pump manifold (2) underneath the gear unit housing and push up until it rests against the gear unit housing.
20. Attach pump manifold (2) to the gear unit housing.
21. Screw pump manifold (2) tightly to gear unit housing.
22. Lubricate O-ring (Fig. 11, Item 6) between pump manifold (2) and inlet valve housing with machine grease. Screw inlet valve housing to the pump manifold.
23. Insert the elbow on the siphon assembly into the bottom of the foot valve housing. Push the retaining clip up into the groove inside the foot valve housing to secure the siphon assembly in position. Place the return tube over the return tube fitting and secure with the clip.
24. Install front cover.

11.4 PS 3.21 CONNECTION DIAGRAM

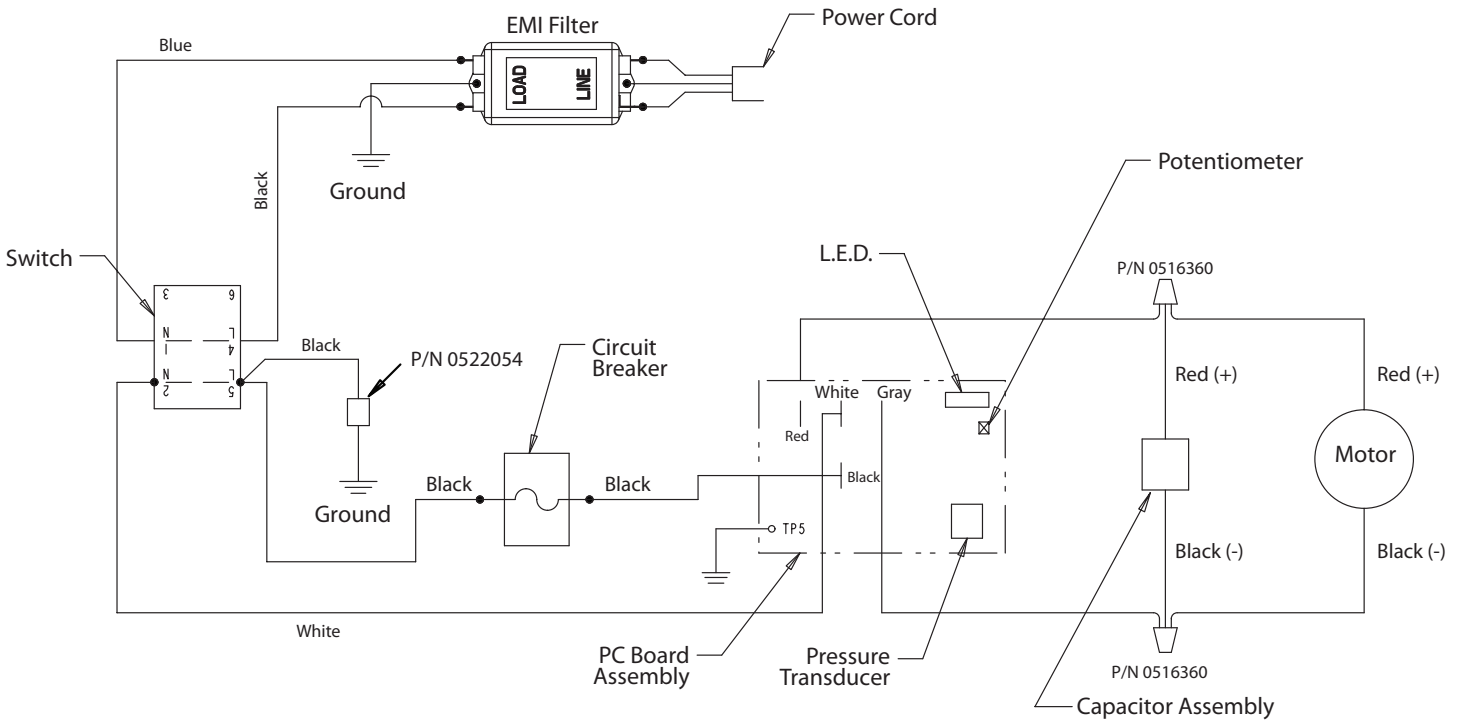





## 12.3 SPRAY GUN ACCESSORIES

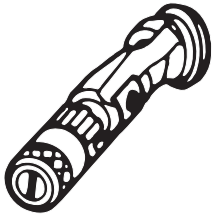

**Flat jet adjusting tip**  
up to 250 bar (25 MPa)

Tip marking	Bore mm	Spray width at about 30 cm removal of spray object Pressure 100 bar (10 MPa)	Use	Flat jet adjusting tip Order No.
15	0.13 - 0.46	5 - 35 cm	Paints	<b>0999 057</b>
20	0.18 - 0.48	5 - 50 cm	Paints, fillers	<b>0999 053</b>
28	0.28 - 0.66	8 - 55 cm	Paints, dispersions	<b>0999 054</b>
41	0.43 - 0.88	10 - 60 cm	Rust protection paints - dispersions	<b>0999 055</b>
49	0.53 - 1.37	10 - 40 cm	Large-area coats	<b>0999 056</b>

### Contact protection

for the flat jet adjustment tip

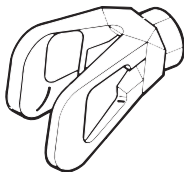

Order No. **0097 294**

### Tip extension with slewable knee joint (without tip)

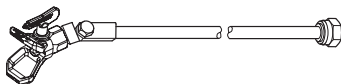

Length: 100 cm    Order no. **0096 015**  
 Length: 200 cm    Order no. **0096 016**  
 Length: 300 cm    Order no. **0096 017**

### Tip extension

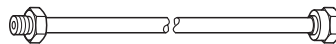

15 cm, F-thread, Order no. **0556 051**  
 30 cm, F-thread, Order no. **0556 052**  
 45 cm, F-thread, Order no. **0556 053**  
 60 cm, F-thread, Order no. **0556 054**

15 cm, G-thread, Order no. **0556 074**  
 30 cm, G-thread, Order no. **0556 075**  
 45 cm, G-thread, Order no. **0556 076**  
 60 cm, G-thread, Order no. **0556 077**

## 12.4 AIRLESS TIP TABLE

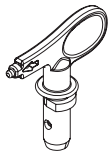

**Wagner TradeTip 3 tip**  
up to 270 bar  
(27 MPa)

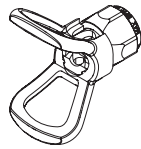

without tip  
F thread (11/16 - 16 UN)  
for Wagner spray guns  
**Order no. 0289391**

without tip  
G thread (7/8 - 14 UN)  
for Graco/Wagner spray guns  
**Order no. 0289390**



All of the tips in the table below are supplied together with the appropriate gun filter.

Application	Tip marking	Spray angle	Bore inch / mm	Spraying width mm 1)	Gun filter	Order no.
Water-thinnable and solvent-based paints and varnishes, oils, separating agents	107	10°	0.007 / 0.18	100	red	0553107
	207	20°	0.007 / 0.18	120	red	0553207
	307	30°	0.007 / 0.18	150	red	0553307
	407	40°	0.007 / 0.18	190	red	0553407
	109	10°	0.009 / 0.23	100	red	0553109
	209	20°	0.009 / 0.23	120	red	0553209
	309	30°	0.009 / 0.23	150	red	0553309
	409	40°	0.009 / 0.23	190	red	0553409
	509	50°	0.009 / 0.23	225	red	0553509
	609	60°	0.009 / 0.23	270	red	0553609
Synthetic-resin paints PVC paints	111	10°	0.011 / 0.28	100	red	0553111
	211	20°	0.011 / 0.28	120	red	0553211
	311	30°	0.011 / 0.28	150	red	0553311
	411	40°	0.011 / 0.28	190	red	0553411
	511	50°	0.011 / 0.28	225	red	0553511
	611	60°	0.011 / 0.28	270	red	0553611
Paints, primers Fillers	113	10°	0.013 / 0.33	100	red	0553113
	213	20°	0.013 / 0.33	120	red	0553213
	313	30°	0.013 / 0.33	150	red	0553313
	413	40°	0.013 / 0.33	190	red	0553413
	513	50°	0.013 / 0.33	225	red	0553513
	613	60°	0.013 / 0.33	270	red	0553613
	813	80°	0.013 / 0.33	330	red	0553813
Fillers Rust protection paints	115	10°	0.015 / 0.38	100	yellow	0553115
	215	20°	0.015 / 0.38	120	yellow	0553215
	315	30°	0.015 / 0.38	150	yellow	0553315
	415	40°	0.015 / 0.38	190	yellow	0553415
	515	50°	0.015 / 0.38	225	yellow	0553515
	615	60°	0.015 / 0.38	270	yellow	0553615
	715	70°	0.015 / 0.38	300	yellow	0553715
	815	80°	0.015 / 0.38	330	yellow	0553815
Rust protection paints Latex paints Dispersions	117	10°	0.017 / 0.43	100	white	0553117
	217	20°	0.017 / 0.43	120	white	0553217
	317	30°	0.017 / 0.43	150	white	0553317
	417	40°	0.017 / 0.43	190	white	0553417
	517	50°	0.017 / 0.43	225	white	0553517
	617	60°	0.017 / 0.43	270	white	0553617
	717	70°	0.017 / 0.43	300	white	0553717
	817	80°	0.017 / 0.43	330	white	0553817
Rust protection paints Latex paints Dispersions	219	20°	0.019 / 0.48	120	white	0553219
	319	30°	0.019 / 0.48	150	white	0553319
	419	40°	0.019 / 0.48	190	white	0553419
	519	50°	0.019 / 0.48	225	white	0553519
	619	60°	0.019 / 0.48	270	white	0553619
	719	70°	0.019 / 0.48	300	white	0553719
	819	80°	0.019 / 0.48	330	white	0553819
	919	90°	0.019 / 0.48	385	white	0553919

1) Spray width at about 30 cm to the object and 100 bar (10 MPa) pressure with synthetic-resin paint 20 DIN seconds.

Application	Tip marking	Spray angle	Bore inch / mm	Spraying width mm 1)	Gun filter	Order no.
Flame retardant	221	20°	0.021 / 0.53	120	white	0553221
	321	30°	0.021 / 0.53	150	white	0553321
	421	40°	0.021 / 0.53	190	white	0553421
	521	50°	0.021 / 0.53	225	white	0553521
	621	60°	0.021 / 0.53	270	white	0553621
	721	70°	0.021 / 0.53	300	white	0553721
	821	80°	0.021 / 0.53	330	white	0553821
	Roof coatings	223	20°	0.023 / 0.58	120	white
323		30°	0.023 / 0.58	150	white	0553323
423		40°	0.023 / 0.58	190	white	0553423
523		50°	0.023 / 0.58	225	white	0553523
623		60°	0.023 / 0.58	270	white	0553623
723		70°	0.023 / 0.58	300	white	0553723
823		80°	0.023 / 0.58	330	white	0553823
Thick-film materials, Corrosion protection Spray filler		225	20°	0.025 / 0.64	120	white
	325	30°	0.025 / 0.64	150	white	0553325
	425	40°	0.025 / 0.64	190	white	0553425
	525	50°	0.025 / 0.64	225	white	0553525
	625	60°	0.025 / 0.64	270	white	0553625
	725	70°	0.025 / 0.64	300	white	0553725
	825	80°	0.025 / 0.64	330	white	0553825
	227	20°	0.027 / 0.69	120	white	0553227
	327	30°	0.027 / 0.69	150	white	0553327
	427	40°	0.027 / 0.69	190	white	0553427
	527	50°	0.027 / 0.69	225	white	0553527
	627	60°	0.027 / 0.69	270	white	0553627
	827	80°	0.027 / 0.69	330	white	0553827
	229	20°	0.029 / 0.75	120	white	0553229
	329	30°	0.029 / 0.75	150	white	0553329
	429	40°	0.029 / 0.75	190	white	0553429
	529	50°	0.029 / 0.75	225	white	0553529
	629	60°	0.029 / 0.75	270	white	0553629
	231	20°	0.031 / 0.79	120	white	0553231
	331	30°	0.031 / 0.79	150	white	0553331
	431	40°	0.031 / 0.79	190	white	0553431
	531	50°	0.031 / 0.79	225	white	0553531
	631	60°	0.031 / 0.79	270	white	0553631
	731	70°	0.031 / 0.79	300	white	0553731
	831	80°	0.031 / 0.79	330	white	0553831
	233	20°	0.033 / 0.83	120	white	0553233
	333	30°	0.033 / 0.83	150	white	0553333
	433	40°	0.033 / 0.83	190	white	0553433
	533	50°	0.033 / 0.83	225	white	0553533
	633	60°	0.033 / 0.83	270	white	0553633
	235	20°	0.035 / 0.90	120	white	0553235
	335	30°	0.035 / 0.90	150	white	0553335
	435	40°	0.035 / 0.90	190	white	0553435
535	50°	0.035 / 0.90	225	white	0553535	
635	60°	0.035 / 0.90	270	white	0553635	
735	70°	0.035 / 0.90	300	white	0553735	
439	40°	0.039 / 0.99	190	white	0553439	
539	50°	0.039 / 0.99	225	white	0553539	
639	60°	0.039 / 0.99	270	white	0553639	
Heavy duty applications	243	20°	0.043 / 1.10	120	green	0553243
	443	40°	0.043 / 1.10	190	green	0553443
	543	50°	0.043 / 1.10	225	green	0553543
	643	60°	0.043 / 1.10	270	green	0553643
	445	40°	0.045 / 1.14	190	green	0553445
	545	50°	0.045 / 1.14	225	green	0553545
	645	60°	0.045 / 1.14	270	green	0553645
	451	40°	0.051 / 1.30	190	green	0553451
	551	50°	0.051 / 1.30	225	green	0553551
	651	60°	0.051 / 1.30	270	green	0553651
	252	20°	0.052 / 1.32	120	green	0553252
	455	40°	0.055 / 1.40	190	green	0553455
	555	50°	0.055 / 1.40	225	green	0553555
	655	60°	0.055 / 1.40	270	green	0553655
	261	20°	0.061 / 1.55	120	green	0553261
	461	40°	0.061 / 1.55	190	green	0553461
	561	50°	0.061 / 1.55	225	green	0553561
	661	60°	0.061 / 1.55	270	green	0553661
	263	20°	0.063 / 1.60	120	green	0553263
	463	40°	0.063 / 1.60	190	green	0553463
	565	50°	0.065 / 1.65	225	green	0553565
	665	60°	0.065 / 1.65	270	green	0553665
	267	20°	0.067 / 1.70	120	green	0553267
467	40°	0.067 / 1.70	190	green	0553467	

1) Spray width at about 30 cm to the object and 100 bar (10 MPa) pressure with synthetic-resin paint 20 DIN seconds.

## 12.5 TEMPSPRAY

The paint material is heated to the required temperature uniformly by an electric heating element, which is located inside the hose (regulated from 20°C to 60°C).

### Advantages:

- Constant paint temperature even at low outside temperatures
- Considerably better working of high viscosity coating materials
- Increased application efficiency
- Savings in solvents due to reduction in viscosity
- Adaptable to all airless units

Order No.	Description
2311659 2311852	<b>TempSpray H 126 (ideal for lacquer jobs)</b> Basic unit 1/4" incl. stainless steel hose, DN6, 1/4", 10m Spraypack consisting of: basic unit (2311659), Airless gun AG 14 NPS 1/4", incl. Trade Tip 2 nozzler holder (F-thread) and Trade Tip 2 Fine Finish 410
2311660 2311853	<b>TempSpray H 226 (ideal for dispersions/materials with high viscosity)</b> Basic unit 1/4" incl. Hose reel, heated hose DN10, 15m, hose 1/4" DN4, 1m Spraypack consisting of: Basic unit (2311660), Airless gun AG 14 NPS 1/4", incl. Trade Tip 2 nozzler holder (F-thread) and Trade Tip 2 nozzle 419
2311661 2311854	<b>TempSpray H 326 (ideal for dispersions/materials with high viscosity)</b> Basic unit 1/4" incl. Hose reel, heated hose DN10, 30m, hose 1/4" DN4, 1m Spraypack consisting of: Basic unit (2311661), Airless gun AG 14 NPS 1/4", incl. Trade Tip 2 nozzler holder (F-thread) and Trade Tip 2 nozzle 421

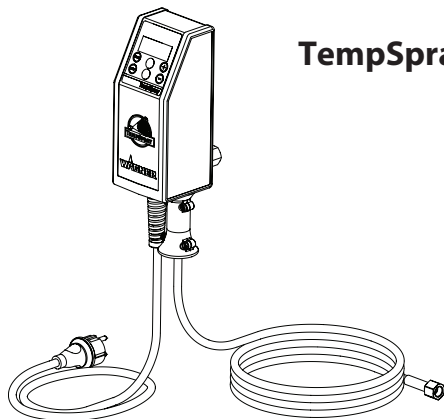

**TempSpray H 126**

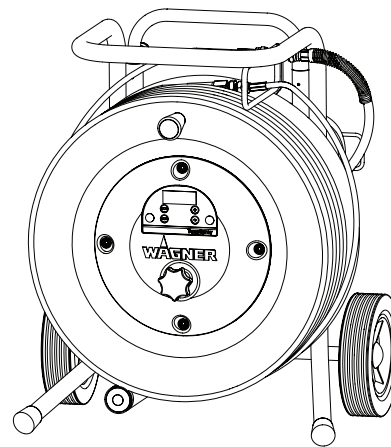

**TempSpray H 226**  
**TempSpray H 326**

## 12.6 PUMP-RUNNER

(Order No. 2306987)

Universal accessories for cleaning, clean transportation and preservation of the pump unit.

### Features:

- Simpler cleaning – the cleaning liquid circulates constantly through the pump making thorough cleaning of the interior
- No cleaning necessary during work stoppage or change of location because the paint in the pump cannot dry out or leak
- Better protection
- Simple assembly

### Suitable for the following models:

Diaphragm Pumps		Double-stroke piston pumps	
SF 21	Finish 270/370	PS 24	PS 3.25
SF 23	Nespray Deco	PS 26	PS 3.29
SF 27	Nespray 31	PS 30	PS 3.31
SF 31		PS 34	PS 3.34
SF 7000			



Order this at the same time:

EasyClean, cleaning and preservation agent (118ml) Order no. 0508 620.

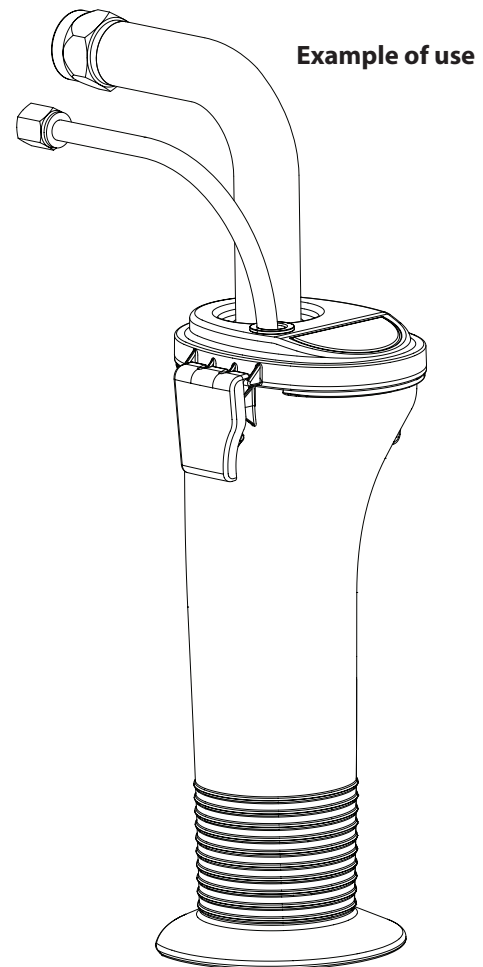
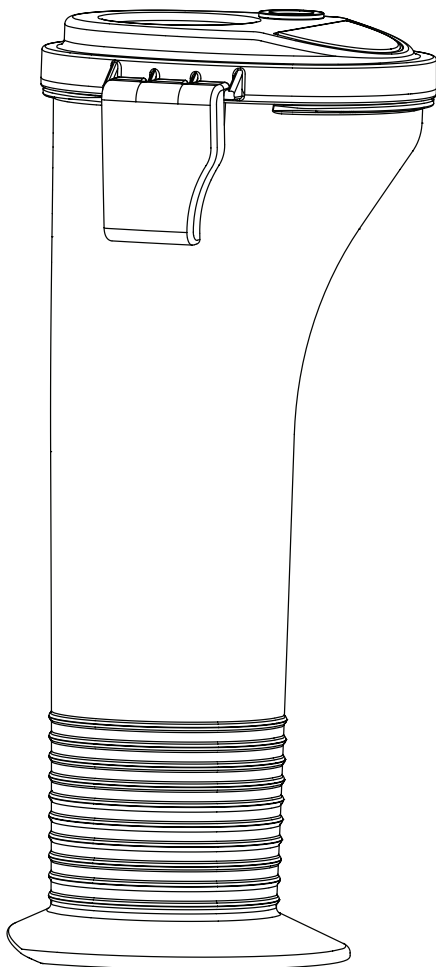

GB ACCESSORIES ILLUSTRATION

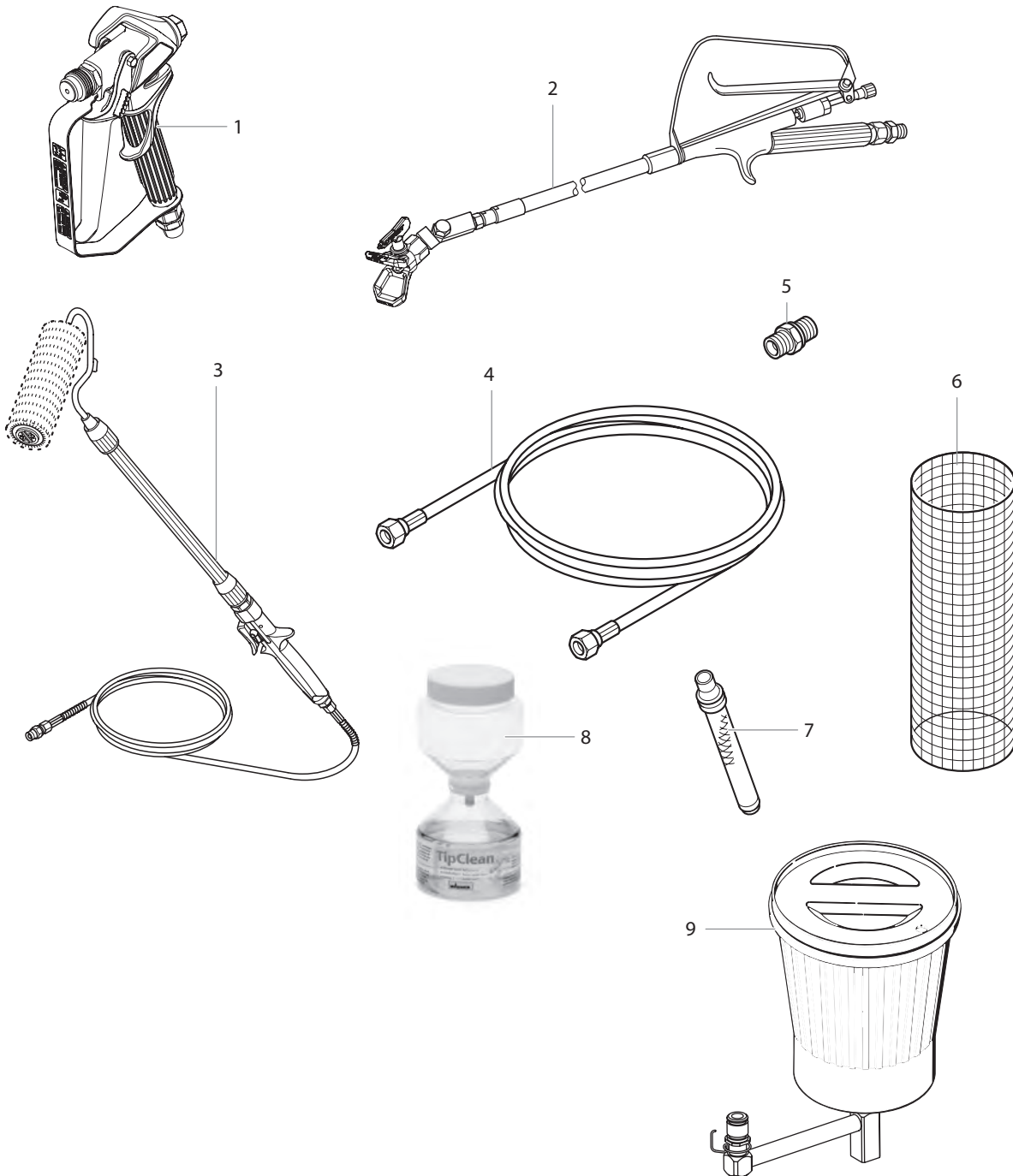

#	PS 3.21	Description
1	0538 041	Spray gun, Vector Pro 2-finger
	0538 040	Spray gun, Vector Pro 4-finger
	0538 042	Spray gun, Vector Grip 2-finger
	0538 043	Spray gun, Vector Grip 4-finger
2	0296 441	Pole gun 120 cm, G-thread 7/8"
	0296 443	Pole gun 120 cm, F-thread 11/16"
	0296 442	Pole gun 200 cm, G-thread 7/8"
	0296 444	Pole gun 200 cm, F-thread 11/16"
3	0345 010	In-line roller IR-100
4	9984 573	High-pressure hose DN 4 mm, 7.5 m with stainless steel nipple, 1/4"
	9984 574	High-pressure hose DN 6 mm, 15 m for dispersion, 1/4"
	9984 575	High-pressure hose DN 6 mm, 30 m for dispersion, 1/4"
5	0034 038	Double socket for coupling high-pressure hoses (1/4" x 1/4")
6	0034 950	Metex-Reuse Reuse for pre-filtering of coating material in vessel. Place suction pipe in the reuse.
	0034 952	Sieve package (5 pcs) for paint
	0034 951	Sieve package (5 pcs) for dispersion
7	0034 383	Gun filter, red, 1 piece; 180 mesh extra fine
	0097 022	Gun filter, red, 10 pieces; 180 mesh extra fine
	0043 235	Gun filter, yellow, 1 piece; 100 mesh fine
	0097 023	Gun filter, yellow, 10 pieces; 100 mesh fine
	0034 377	Gun filter, white, 1 piece; 50 mesh medium
	0097 024	Gun filter, white, 10 pieces; 50 mesh medium
	0089 323	Gun filter, green, 1 piece; 30 mesh coarse
	0097 025	Gun filter, green, 10 pieces; 30 mesh coarse
8	0097 108	TipClean Cleaning Set for easy cleaning and conservation of nozzles
	0508 619	EasyGlide, special oil (118ml)
	0508 620	EasyClean, cleaning and conservation agent (118 ml)
9	0551 969	Hopper kit

GB MAIN ASSEMBLY

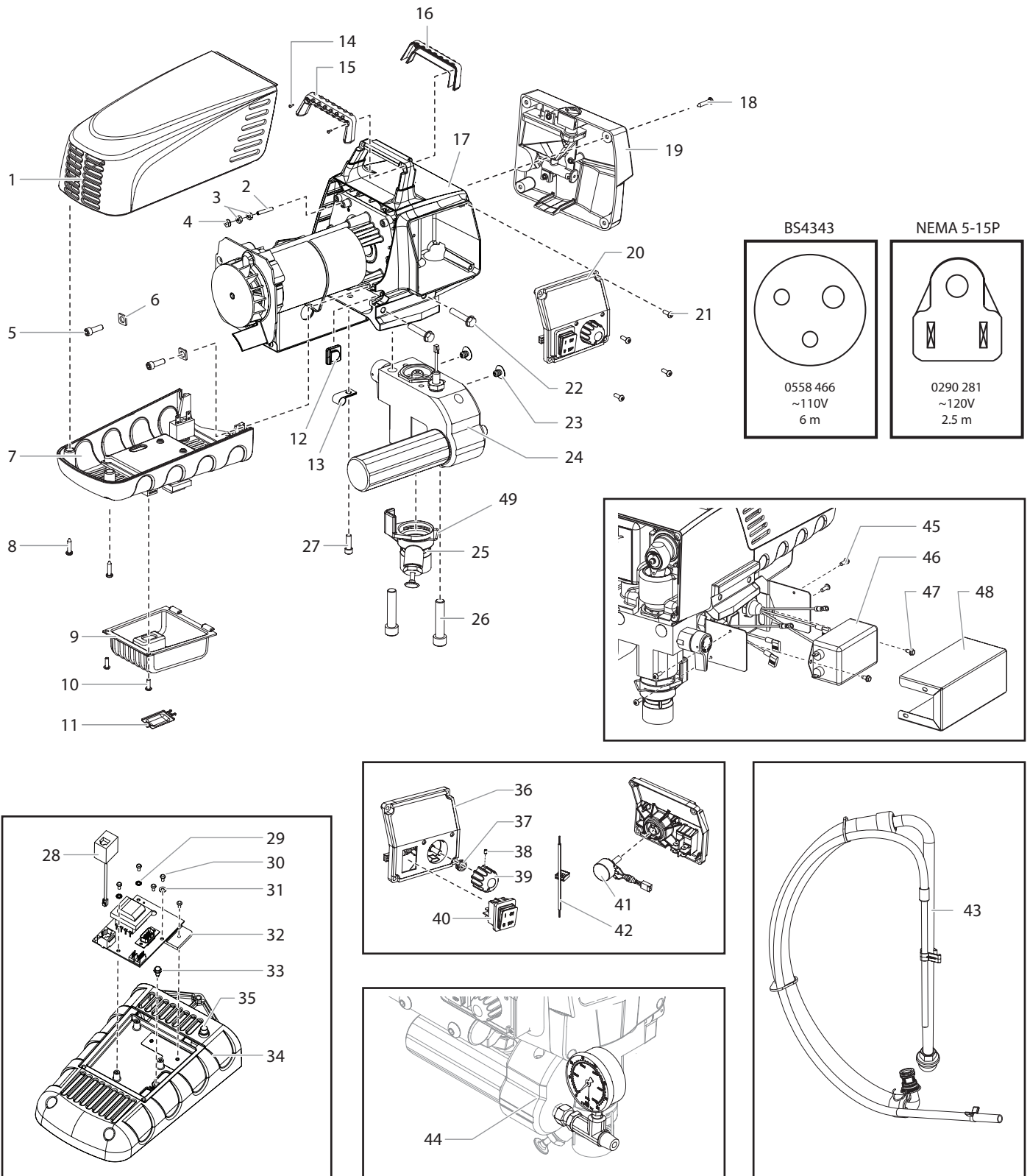



#	PS 3.21	Description
1	0290 230	Motor shroud
2	9805 403	Set screw
3	9810 103	Nut
4	0524 353	Nut
5	9800 319	Screw (2)
6	9822 627	Washer (2)
7	0558 332A	Belly pan assembly (includes items 28-34)
8	9802 266	Screw (2)
9	0558 408	Dust cover
10	0509 218	Screw (2)
11	0290 222	Door
12	0558 460	Plug*
13	-----	Strap*
14	9805 317	Screw (2)
15	0290 212	Handle cover, back
16	0290 213	Handle cover, front
17	-----	Drive assembly
18	0509 218	Screw (4)
19	0290 278	Face plate / oiler assembly
20	0558 305A	Control panel assembly, complete (includes items 36-42)
21	0509 218	Screw (4)
22	9805 348	Screw (4)
23	0509 636	Plug (2)
24	0558 298A	Fluid section assembly
25	0290 205	Pusher assembly (includes item 49)

#	PS 3.21	Description
26	0508 553	Screw (2)
27	9800 319	Screw
28	0551 757	Transducer jumper
29	9822 624	Washer (2)
30	9800 607	Screw (5)
31	54054	Washer
32	0290 221	PC board assembly
33	9800 340	Screw
34	0290 231	Belly pan
35	0551 515	Circuit breaker
36	0290 227	Control panel cover with label
37	0507 749A	Nut with seal
38	0290 202	Set screw
39	0290 218	Knob
40	9850 936	Switch
41	0508 579	Potentiometer
42	0522 007	LED assembly
43	0558 672	Siphon assembly
44	0508 239	Manometer
45	0509 218	Screw (4)*
46	0522 424	EMI filter, 20A*
47	9800 340	Ground screw (2)*
48	0558 452	Bracket cover (2)*
49	0558 742	Clip
	0522 052	Wire assembly (not shown)

\* UK only

GB FLUID SECTION

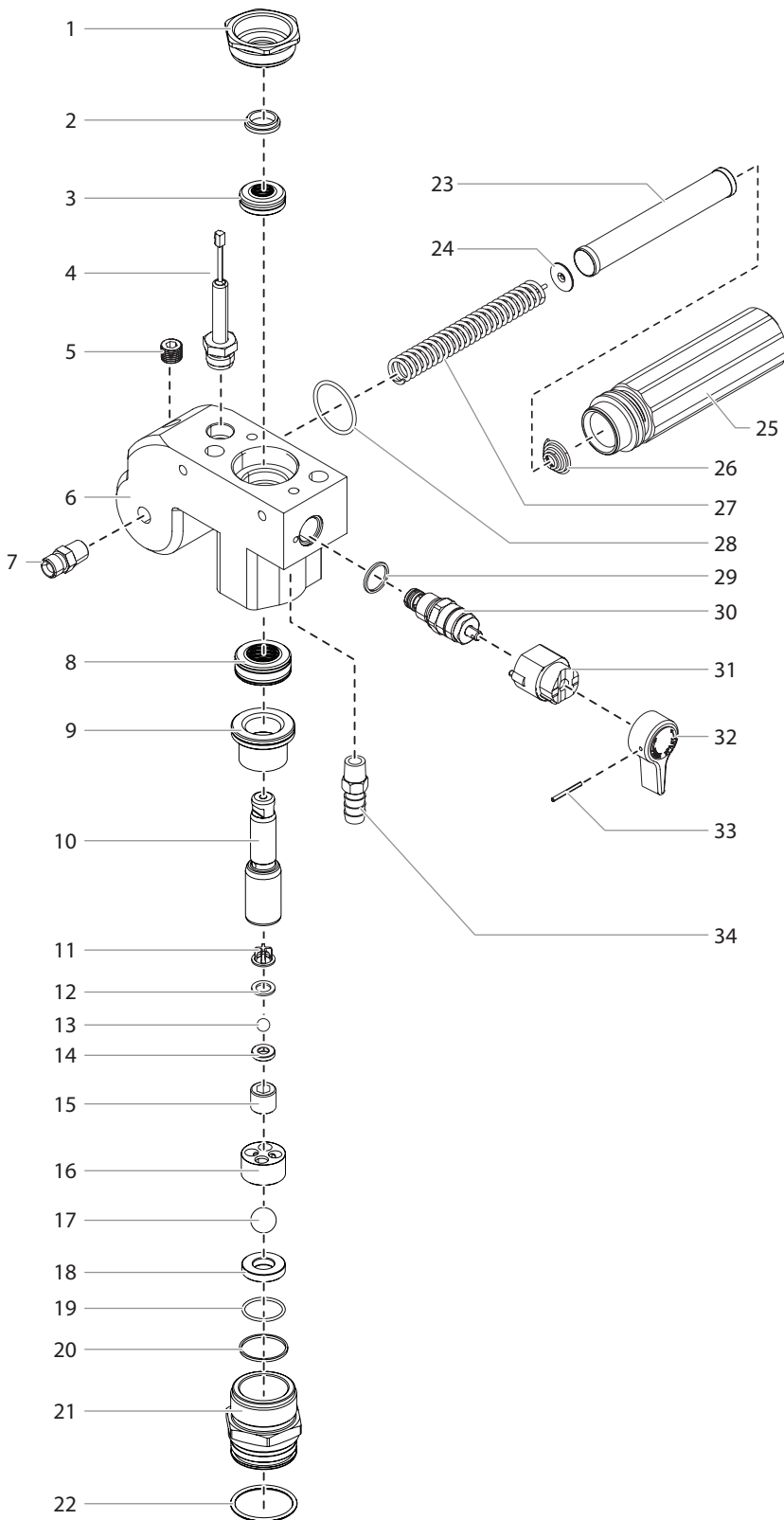

#	PS 3.21	Description
1	0509 594	Retainer
2	0509 584	Piston guide
3	-----	Upper packing
4	0551 756	Transducer assembly
5	0507 517	Pipe plug
6	0290 209	Pump manifold
7	0509 873	Fitting
8	-----	Lower packing
9	0552 489	Bushing
10	0290 277	Piston rod
11	0551 262	Upper cage
12	0551 263	Crush washer
13	50164	Outlet valve ball
14	0551 620	Outlet valve seat
15	13481	Outlet valve retainer
16	0509 591	Lower ball guide
17	0509 583	Inlet valve ball
18	0551 534	Inlet valve seat
19	0509 582	O-ring, PTFE
20	0509 581	Inlet valve seal
21	0290 216	Inlet valve housing
22	9871 160	O-ring
23	0508 748	Filter
24	0508 603	Bearing ring
25	0508 601	Filter housing
26	0508 602	Conical spring
27	0508 749	Bearing spring
28	0508 604	O-ring
29	0507 745	Gasket
30	0558 727	Bypass valve assembly (includes item 29)
31	0507 931	Cam base
32	0508 744	Relief valve knob
33	5006 543	Groove pin
34	193-200	Return tube fitting
	0509 151	Piston assembly (includes items 10-15)
	0290 201	Repacking kit - 1 (includes items 2-3, 8, 11-13, 17 and 19-20).
	0558 728	Repacking kit - 2 (includes items 2-3 and 8)
	0507 254	Relief valve w/ handle (includes items 29 – 33)

GB DRIVE ASSEMBLY

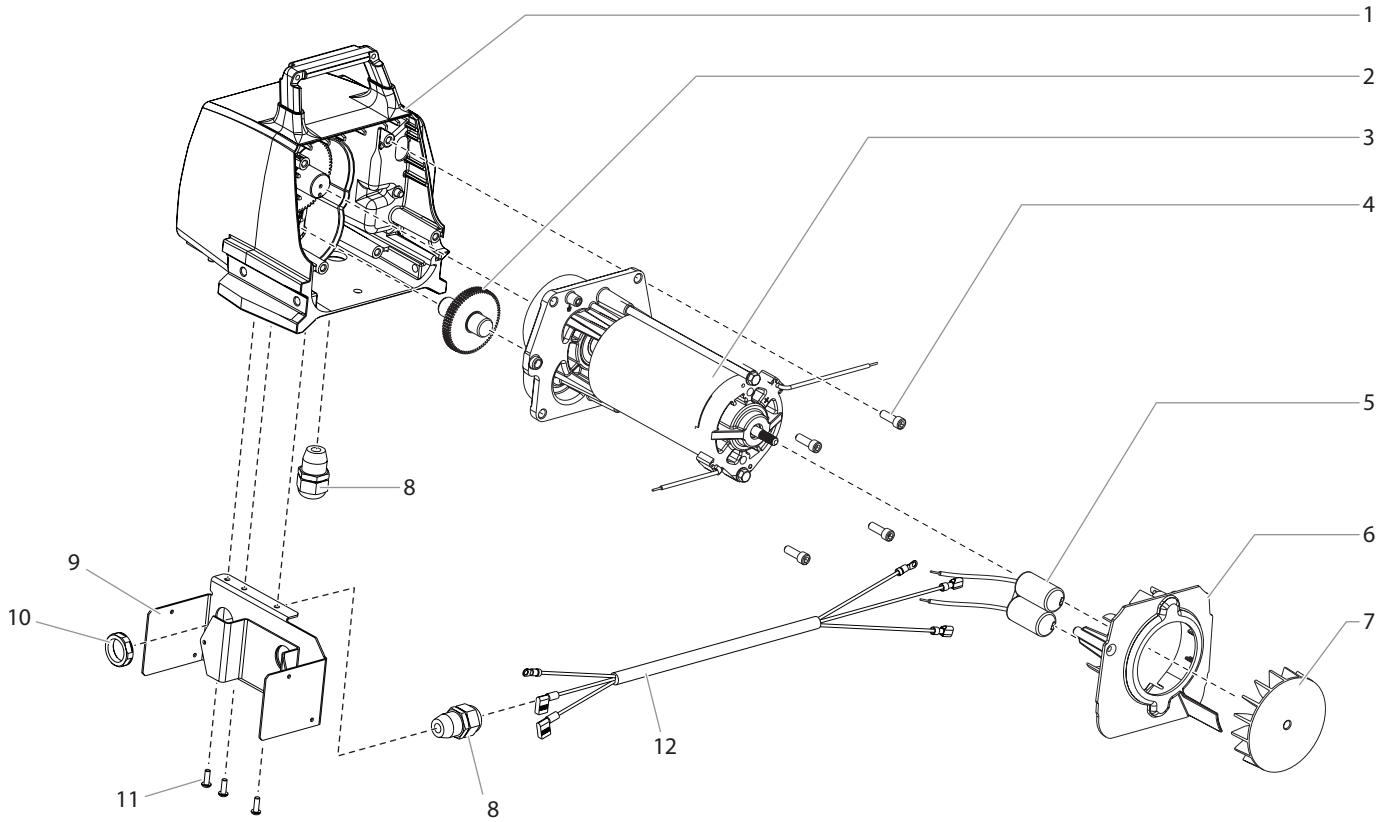

#	PS 3.21	Description
1	0524 637A	Housing assembly
2	0509 121	2nd stage gear
3	0558 373	Motor assembly, 120V (includes items 5-7)
4	9800 319	Screw (4)
5	0522 018	Capacitor assembly
6	0290 217	Baffle assembly
7	0512 340	Fan
8	0551 714	Cord grip (2)*
9	0558 449	Bracket*
10	0551 980	Lock nut*
11	0509 218	Screw (3)*
12	0558 476	Power cord jumper*
	-----	Double sided tape (not shown)
	0551 543	Tie wrap (not shown)
	0508 645	Motor brush kit

\* UK only

GB STAND

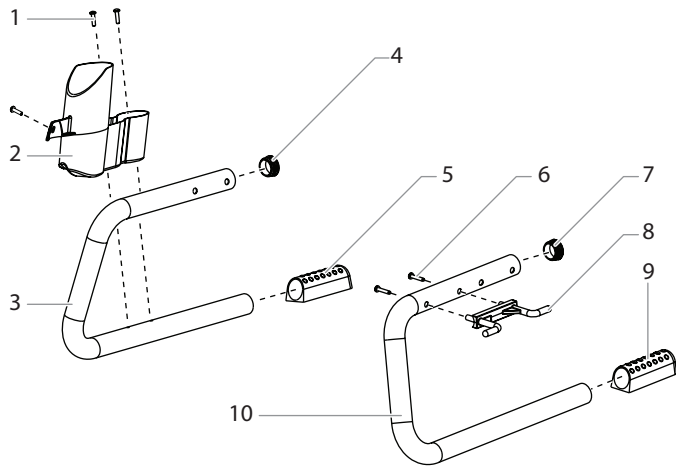

GB SUCTION SYSTEM FOR STAND

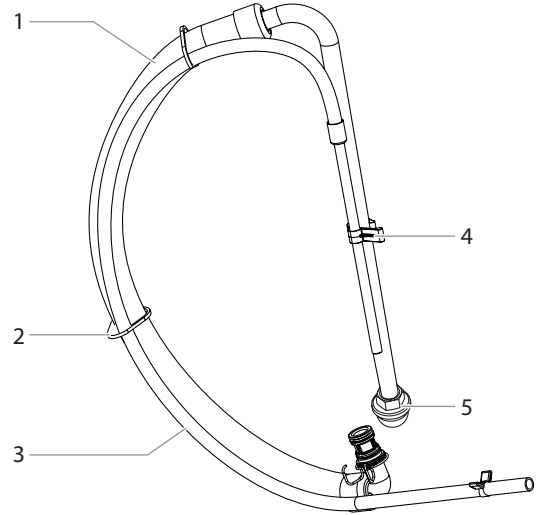

#	PS 3.21	Description
1	9805 367	Screw (3)
2	0290 215	Drip cup
3	0290 211	Leg, right
4	0294 635	Plug
5	0290 214	Foot
6	0508 660	Screw (2)
7	0294 635	Plug
8	0290 219	Cord holder
9	0290 214	Foot
10	0290 210	Leg, left
	0290 203	Left leg assembly (includes items 6-10)
	0290 204	Right leg assembly (includes items 1-5)

#	PS 3.21	Description
1	0551 706	Siphon hose
2	9850 638	Tie wrap (2)
3	0558 659A	Return tube
4	0279 459	Clip
5	0295 565	Inlet screen
	0558 672	Siphon tube assembly (includes items 1-5)

**IMPORTANT NOTES ON PRODUCT LIABILITY**

As a result of an EC regulation being effective as from January 1, 1990, the manufacturer shall only be liable for his product if all parts come from him or are released by him, and if the devices are properly mounted and operated.

If the user applies outside accessories and spare parts, the manufacturer's liability can fully or partially be inapplicable; in extreme cases usage of the entire device can be prohibited by the competent authorities (employer's liability insurance association and factory inspectorate division).

Only the usage of original WAGNER accessories and spare parts guarantees that all safety regulations are observed.

**3+2 YEARS GUARANTEE FOR PROFESSIONAL FINISHING**

Wagner professional guarantee  
(Status 01.02.2009)

**1. Scope of guarantee**

All Wagner professional colour application devices (hereafter referred to as products) are carefully inspected, tested and are subject to strict checks under Wagner quality assurance. Wagner exclusively issues extended guarantees to commercial or professional users (hereafter referred to as "customer") who have purchased the product in an authorised specialist shop, and which relate to the products listed for that customer on the Internet under [www.wagner-group.com/profi-guarantee](http://www.wagner-group.com/profi-guarantee).

The buyer's claim for liability for defects from the purchase agreement with the seller as well as statutory rights are not impaired by this guarantee.

We provide a guarantee in that we decide whether to replace or repair the product or individual parts, or take the device back and reimburse the purchase price. The costs for materials and working hours are our responsibility. Replaced products or parts become our property.

**2. Guarantee period and registration**

The guarantee period amounts to 36 months. For industrial use or equal wear, such as shift operations in particular, or in the event of rentals it amounts to 12 months.

Systems driven by petrol or air are also guaranteed for a 12 month period.

The guarantee period begins with the day of delivery by the authorised specialist shop. The date on the original purchase document is authoritative.

For all products bought in authorised specialist shops from 01.02.2009 the guarantee period is extended to 24 months providing the buyer of these devices registers in accordance with the following conditions within 4 weeks of the day of delivery by the authorised specialist shop.

Registration can be completed on the Internet under [www.wagner-group.com/profi-guarantee](http://www.wagner-group.com/profi-guarantee). The guarantee certificate is valid as confirmation, as is the original purchase document that carries the date of the purchase. Registration is only possible if the buyer is in agreement with having the data being stored that is entered during registration.

When services are carried out under guarantee the guarantee period for the product is neither extended nor renewed.

Once the guarantee period has expired, claims made against the guarantee or from the guarantee can no longer be enforced.

**3. Handling**

If defects can be seen in the materials, processing or performance of the device during the guarantee period, guarantee claims must be made immediately, or at the latest within a period of 2 weeks.

The authorised specialist shop that delivered the device is entitled to accept guarantee claims. Guarantee claims may also be made to the service centres named in our operating instructions. The product has to be sent without charge or presented together with the original purchase document that includes details of the purchase date and the name of the product. In order to claim for an extension to the guarantee, the guarantee certificate must be included.

The costs as well as the risk of loss or damage to the product in transit or by the centre that accepts the guarantee claims or who delivers the repaired product, are the responsibility of the customer.

**4. Exclusion of guarantee**

Guarantee claims cannot be considered

- for parts that are subject to wear and tear due to use or other natural wear and tear, as well as defects in the product that are a result of natural wear and tear, or wear and tear due to use. This includes in particular cables, valves, packaging, jets, cylinders, pistons, means-carrying housing components, filters, pipes, seals, rotors, stators, etc. Damage due to wear and tear that is caused in particular by sanded coating materials, such as dispersions, plaster, putty, adhesives, glazes, quartz foundation.
- in the event of errors in devices that are due to non-compliance with the operating instructions, unsuitable or unprofessional use, incorrect assembly and/or commissioning by the buyer or by a third party, or utilisation other than is intended, abnormal ambient conditions, unsuitable coating materials, unsuitable operating conditions, operation with the incorrect mains voltage supply/frequency, over-operation or defective servicing or care and/or cleaning.
- for errors in the device that have been caused by using accessory parts, additional components or spare parts that are not original Wagner parts.
- for products to which modifications or additions have been carried out.
- for products where the serial number has been removed or is illegible
- for products to which attempts at repairs have been carried out by unauthorised persons.
- for products with slight deviations from the target properties, which are negligible with regard to the value and usability of the device.
- for products that have been partially or fully taken apart.

**5. Additional regulations.**

The above guarantees apply exclusively to products that have been bought by authorised specialist shops in the EU, CIS, Australia and are used within the reference country.

If the check shows that the case is not a guarantee case, repairs are carried out at the expense of the buyer.

The above regulations manage the legal relationship to us conclusively. Additional claims, in particular for damages and losses of any type, which occur as a result of the product or its use, are excluded from the product liability act except with regard to the area of application.

Claims for liability for defects to the specialist trader remain unaffected.

German law applies to this guarantee. The contractual language is German. In the event that the meaning of the German and a foreign text of this guarantee deviate from one another, the meaning of the German text has priority.

**J. Wagner GmbH**  
**Division Professional Finishing**  
**Otto Lilienthal Strasse 18**  
**88677 Markdorf**  
**Federal Republic of Germany**

<b>- GB -</b>
<p>Note on disposal:</p> <p>In observance of the European Directive 2002/96/EC on waste electrical and electronic equipment and implementation in accordance with national law, this product is not to be disposed of together with household waste material but must be recycled in an environmentally friendly way!</p> <p>Wagner or one of our dealers will take back your used Wagner waste electrical or electronic equipment and will dispose of it for you in an environmentally friendly way. Please ask your local Wagner service centre or dealer for details or contact us direct.</p>



<b>GB</b>	<p><b>EU Declaration of conformity</b></p> <p>We declare under sole responsibility that this product conforms to the following relevant stipulations: 2006/42/EC, 2014/30/EU, 2011/65/EU, 2012/19/EU</p> <p>Applied harmonised norms: EN ISO 12100, EN 1953, EN 60204-1, EN 61000-3-2, EN 61000-3-3, EN 61000-6-1, EN 61000-6-3,</p> <p>The EU declaration of conformity is enclosed with the product. If required, it can be re-ordered using order number <b>2385803</b>.</p>
<b>D</b>	<p><b>EU Konformitätserklärung</b></p> <p>Wir erklären in alleiniger Verantwortung, dass dieses Produkt den folgenden einschlägigen Bestimmungen entspricht: 2006/42/EG, 2014/30/EU, 2011/65/EU, 2012/19/EU</p> <p>Angewandte harmonisierte Normen: EN ISO 12100, EN 1953, EN 60204-1, EN 61000-3-2, EN 61000-3-3, EN 61000-6-1, EN 61000-6-3</p> <p>Die EU Konformitätserklärung liegt dem Produkt bei. Sie kann bei Bedarf mit der Bestellnummer <b>2385803</b> nachbestellt werden.</p>
<b>F</b>	<p><b>Déclaration de conformité UE</b></p> <p>Nous déclarons sous notre responsabilité que ce produit est en conformité avec les réglementations suivantes: 2006/42/CE, 2014/30/UE, 2011/65/UE, 2012/19/UE</p> <p>Conforme aux normes et documents normalisés: EN ISO 12100, EN 1953, EN 60204-1, EN 61000-3-2, EN 61000-3-3, EN 61000-6-1, EN 61000-6-3</p> <p>La déclaration de conformité UE est jointe à ce produit. Elle peut être commandée au besoin sous le numéro de commande <b>2385803</b>.</p>
<b>I</b>	<p><b>Dichiarazione di conformità UE</b></p> <p>Dichiariamo sotto la nostra esclusiva responsabilità, che il presente prodotto corrisponde alle relative disposizioni seguenti: 2006/42/CE, 2014/30/UE, 2011/65/UE, 2012/19/UE</p> <p>Norme armonizzate: EN ISO 12100, EN 1953, EN 60204-1, EN 61000-3-2, EN 61000-3-3, EN 61000-6-1, EN 61000-6-3</p> <p>La dichiarazione di conformità UE è allegata al prodotto. Se necessario, può esserne richiesta una copia con il numero d'ordine <b>2385803</b>.</p>
<b>E</b>	<p><b>Declaración UE de conformidad</b></p> <p>Mediante la presente garantizamos, bajo nuestra exclusiva responsabilidad, que este producto cumple con las correspondientes disposiciones: 2006/42/CE, 2014/30/UE, 2011/65/UE, 2012/19/UE</p> <p>Normas armonizadas aplicadas: EN ISO 12100, EN 1953, EN 60204-1, EN 61000-3-2, EN 61000-3-3, EN 61000-6-1, EN 61000-6-3</p> <p>El producto viene acompañado de la declaración UE de conformidad. Si lo necesita, puede pedirla adicionalmente por el número de pedido <b>2385803</b>.</p>

<b>NL</b>	<p><b>EU-conformiteitsverklaring</b></p> <p>Wij verklaren dat dit product voldoet aan de volgende normen: 2006/42/EG, 2014/30/EU, 2011/65/EU, 2012/19/EU</p> <p>En normatieve documenten: EN ISO 12100, EN 1953, EN 60204-1, EN 61000-3-2, EN 61000-3-3, EN 61000-6-1, EN 61000-6-3</p> <p>De EU-conformiteitsverklaring wordt met het product meegeleverd. Indien nodig kan de verklaring met bestelnummer <b>2385803</b> worden nabesteld.</p>
<b>DK</b>	<p><b>EU Overensstemmelseserklæring</b></p> <p>Vi erklærer under almindeligt ansvar, at dette produkt er i overensstemmelse med følgende bestemmelser: 2006/42/EF, 2014/30/EU, 2011/65/EU, 2012/19/EU</p> <p>Anvendte harmoniserede normer: EN ISO 12100, EN 1953, EN 60204-1, EN 61000-3-2, EN 61000-3-3, EN 61000-6-1, EN 61000-6-3</p> <p>EU Overensstemmelseserklæringen er vedlagt produktet. Om nødvendigt kan den efterbestilles med bestillingsnummer <b>2385803</b>.</p>
<b>S</b>	<p><b>EU Konformitetsförklaring</b></p> <p>Vi intygar och ansvarar för, att denna produkt överensstämmer med följande norm och dokument: 2006/42/EG, 2014/30/EU, 2011/65/EU, 2012/19/EU</p> <p>Använta harmoniserade normer: EN ISO 12100, EN 1953, EN 60204-1, EN 61000-3-2, EN 61000-3-3, EN 61000-6-1, EN 61000-6-3</p> <p>EU-konformitetsförklaringen medföljer produkten. Den kan vid behov beställas genom ordernummer <b>2385803</b>.</p>
<b>P</b>	<p><b>Declaração de Conformidade UE</b></p> <p>Pela presente garantimos, sob a nossa exclusiva responsabilidade, que este produto cumpre com as correspondentes disposições: 2006/42/CE, 2014/30/UE, 2011/65/UE, 2012/19/UE</p> <p>Normas harmonizadas aplicadas: EN ISO 12100, EN 1953, EN 60204-1, EN 61000-3-2, EN 61000-3-3, EN 61000-6-1, EN 61000-6-3</p> <p>A Declaração de Conformidade EU é fornecida juntamente com o produto. Se necessário, pode ser pedido novo exemplar desta declaração com o número de encomenda <b>2385803</b>.</p>

**Berlin**

J. Wagner GmbH  
Service-Stützpunkt  
Flottenstraße 28–42  
13407 Berlin  
Tel. 0 30/ 41 10 93 86  
Telefax 0 30 / 41 10 93 87

**Grünstadt**

J. Wagner GmbH  
Service-Stützpunkt  
Dieselstraße 1  
67269 Grünstadt  
Tel. 0 63 59/ 87 27 55 0  
Telefax 0 63 59/ 80 74 80

**Ratingen**

J. Wagner GmbH  
Service-Stützpunkt  
Siemensstraße 6-10  
40885 Ratingen  
Tel. 0 21 02 / 3 10 37  
Telefax 0 21 02 / 3 43 95

**Heidersdorf in Sachsen**

J. Wagner GmbH  
Service-Stützpunkt  
Olbernhauer Straße 11  
09526 Heidersdorf  
Tel. 03 73 61 / 1 57 07  
Telefax 03 73 61 / 1 57 08

**Hannover**

J. Wagner GmbH  
Service-Stützpunkt  
Kornstraße 20  
31535 Neustadt  
Tel. 0 50 32-8 00 06 23  
Telefax 0 50 32-8 00 06 24

**München**

Jahnke GmbH  
Hochstraße 7  
82024 Taufkirchen  
Tel. 0 89 /6 14 00 22  
Telefax 0 89 / 6 14 04 33  
email: info@airless.de  
www.airless.de

**Nürnberg**

Grimmer GmbH  
Starenweg 28  
91126 Schwabach  
Tel. 0 91 22 / 7 94 73  
Telefax 0 91 22 / 7 94 75 0  
email: info@grimmer-sc.de  
www.grimmer-sc.de

**Markdorf – Zentrale**

J. WAGNER GmbH  
Otto-Lilienthal-Straße 18  
88677 Markdorf  
Postfach 11 20  
88669 Markdorf  
Tel. 0 75 44 / 505-0  
Telefax 0 75 44 / 505-1200  
www.wagner-group.com

**Kundenzentrum**

Tel. 0 75 44 / 505-1666  
Telefax 0 75 44 / 505-1155  
email: kundenzentrum@wagner-group.com

**Technischer Service**

Tel. 0180 5 59 24 637  
(14 Cent/Minute aus dem deutschen  
Festnetz, Mobilfunk max. 42 Cent/Min)

**WAGNER KONTAKTNETZ DEUTSCHLAND, IM INTERNET ZU FINDEN UNTER: WWW.WAGNER-GROUP.COM/PROFI**

- A** J. Wagner Ges.m.b.H.  
Ottogasse 2/20  
2333 Leopoldsdorf  
Österreich  
Tel. +43/ 2235 / 44 158  
Telefax +43/ 2235 / 44 163  
office@wagner-group.at
- B** WSB Finishing Equipment  
Veilinglaan 56-58  
1861 Meise-Wolvertem  
Belgium  
Tel. +32/2/269 46 75  
Telefax +32/2/269 78 45  
info@wagner-wsb.nl
- CH** Wagner International AG  
Industriestrasse 22  
9450 Altstätten  
Schweiz  
Tel. +41/71 / 7 57 22 11  
Telefax +41/71 / 7 57 22 22  
wagner@wagner-group.ch
- D** J. Wagner GmbH  
Otto-Lilienthal-Straße 18  
D-88677 Markdorf  
Postfach 11 20  
D-88669 Markdorf  
Deutschland  
Tel.: +49 / 75 44 / 505 -1664  
Fax: +49 / 75 44 / 505 -1155  
wagner@wagner-group.com  
www.wagner-group.com
- CZ** E-Coreco s.r.o.  
Na Roudné 102  
301 00 Plzeň  
Czechia  
Tel. +420 734 792 823  
Telefax 420 227 077 364  
info@aplikacebarev.cz
- DK** Wagner Spraytech  
Scandinavia A/S  
Helgeshøj Allé 28  
2630 Taastrup  
Denmark  
Tel. +45/43/ 27 18 18  
Telefax +45/43/ 43 05 28  
wagner@wagner-group.dk
- E** Makimport Herramientas, S.L.  
C/ Méjico nº 6  
Pol. El Descubrimiento  
28806 Alcalá de Henares (Madrid)  
Tel. 902 199 021/ 91 879 72 00  
Telefax 91 883 19 59  
ventas@grupo-k.es  
info@grupo-k.es
- F** Euromair Antony  
S.A.V. Ile-de-France  
12-14, av. F. Sommer  
92160 Antony  
Tel. 01.55.59.92.42  
Telefax +33 (0) 1 69 81 72 57  
conseil.paris@euromair.com
- F** Euromair Distribution  
Siège Social / S.A.V. Sud  
343, bd. F. Perrin  
13106 Rousset Cedex  
Tel. 04.42.29.08.96  
Telefax 04.42.53.44.36  
conseil@euromair.com
- GB** Wagner Spraytech (UK) Limited  
The Coach House  
2 Main Road  
Middleton Cheney OX17 2ND  
Great Britain  
UK-Helpline 01295 714200  
Fax 01295 710100  
enquiries@wagnerspraytech.co.uk
- I** Wagner S.p.A.  
23868 Valmadrera (Lc)  
Via Santa Vecchia, 109  
Italia  
Tel./Fax 0341 210100 (centralino)  
wagner\_it\_va@wagner-group.com
- NL** WSB Finishing Equipment BV  
De Heldinnenlaan 200,  
3543 MB Utrecht  
Netherlands  
Tel. +31/ 30/241 41 55  
Telefax +31/ 30/241 17 87  
info@wagner-wsb.nl
- S** Wagner Spraytech  
Scandinavia A/S  
Helgeshøj Allé 28  
2630 Taastrup  
Denmark  
Tel. +45/43/ 21 18 18  
Telefax +45/43/ 43 05 28  
wagner@wagner-group.dk
- RU** ООО Мефферт Полилюкс  
142407 Россия, Московская обл,  
Ногинский р-н, территория  
«Ногинск-Технопарк» д.14  
Tel. +7 495 221 6666  
Telefax +7 495 99 55 88 2  
2216666@m-p-l.ru  
dis@m-p-l.ru